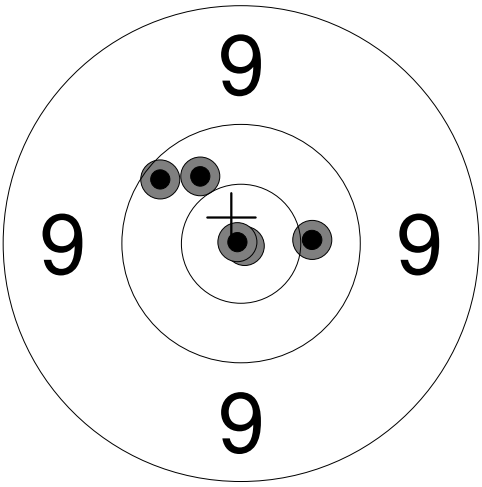
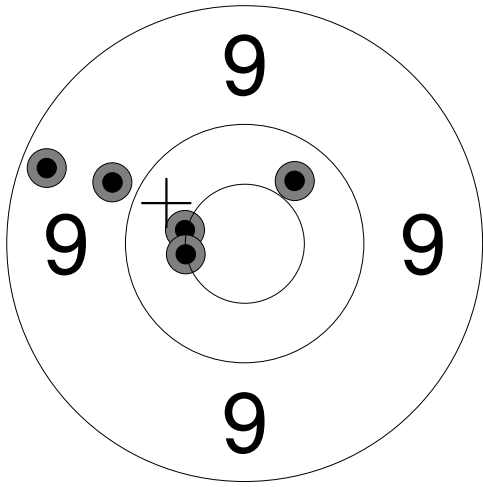
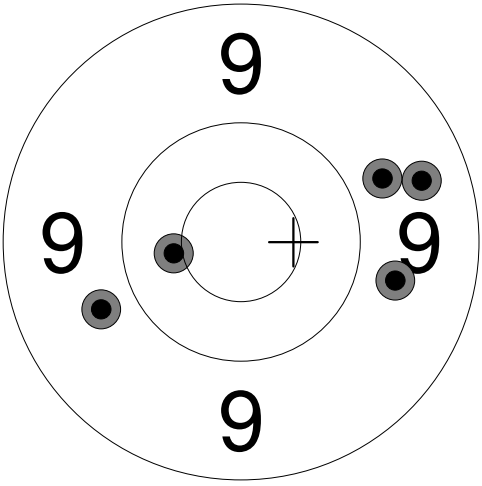
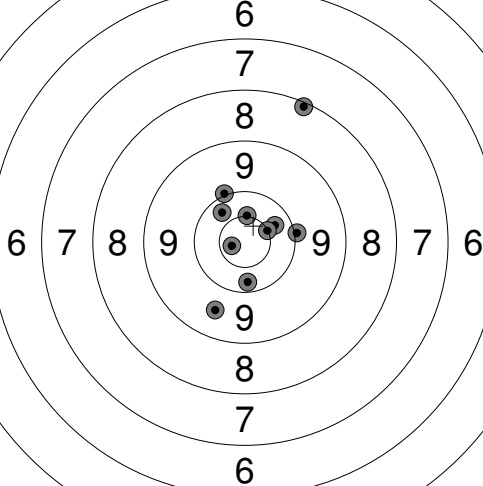
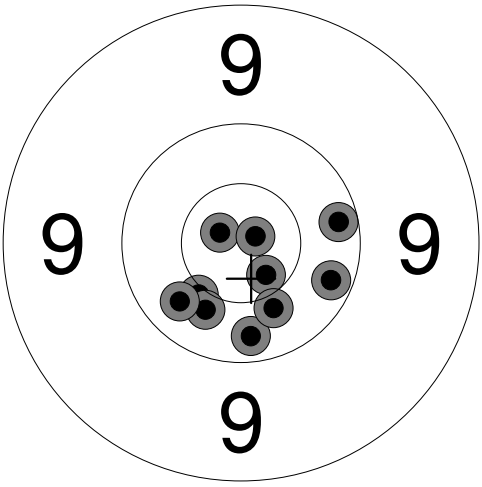
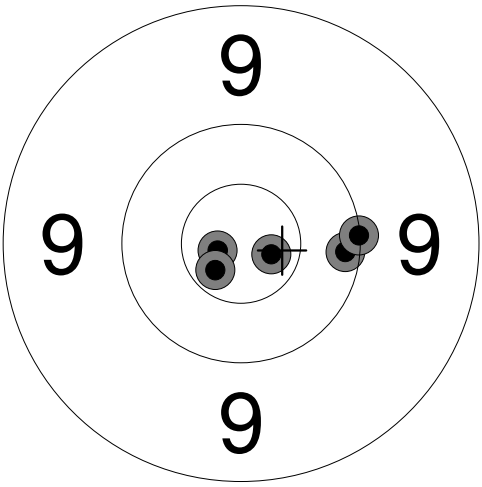
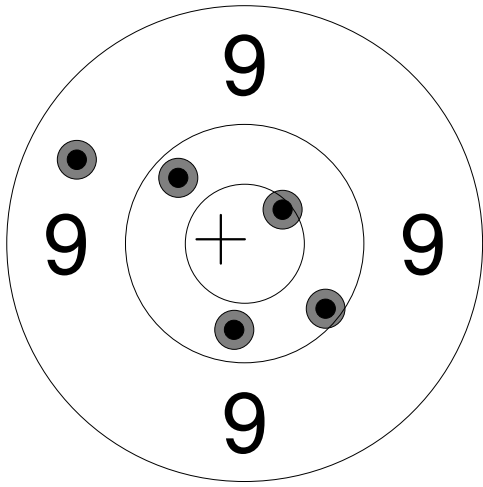
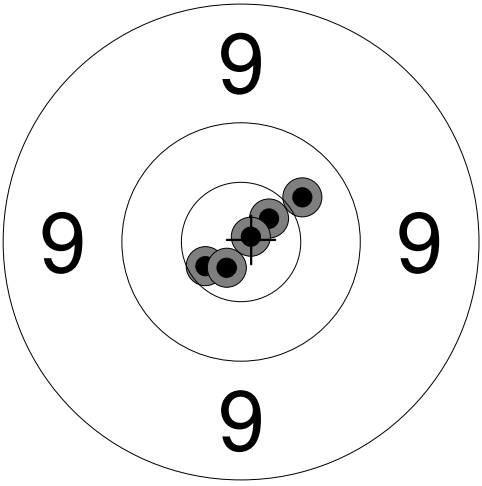
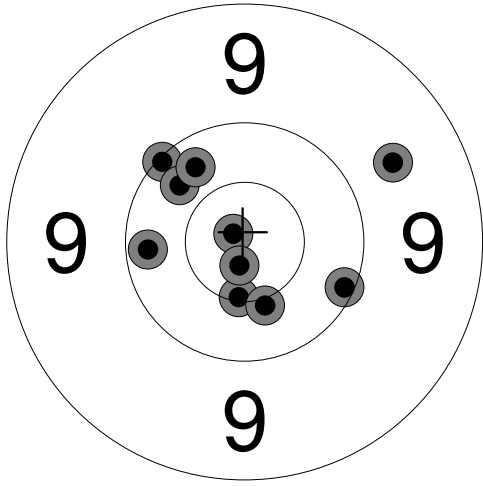

<p>Ligg</p> 	<p>1: 10.4 →</p> <p>2: *10.9 ↘</p> <p>3: 10.2 ↖</p> <p>4: 10.4 ↗</p> <p>5: *10.9 ↖</p>	<p>Stå</p> 	<p>1: 9.8 ↖</p> <p>2: *10.5 ↖</p> <p>3: *10.5 ↖</p> <p>4: 9.2 ↖</p> <p>5: 10.4 ↗</p>
Serie 50.0		Serie 48.0	
Total 50.0		Total 98.0	

<p>Kne</p> 	<p>1: *10.5 ↖</p> <p>2: 9.7 ↖</p> <p>3: 9.4 →</p> <p>4: 9.7 →</p> <p>5: 9.7 →</p>	<p>Grunnlag</p> 	<p>1: 8.1 ↗</p> <p>2: 9.6 ↘</p> <p>3: 10.2 ↓</p> <p>4: 10.0 ↗</p> <p>5: 10.3 ↖</p> <p>6: *10.8 ↖</p> <p>7: 10.0 →</p> <p>8: *10.5 ↑</p> <p>9: 10.3 →</p> <p>10: *10.5 →</p>
Serie 46.0		Serie 97.0	
Total 144.0		Total 241.0	

<p>Finale</p> 	<p>1: 10.2 →</p> <p>2: *10.7 ↘</p> <p>3: 10.2 ↓</p> <p>4: *10.8 ↖</p> <p>5: *10.5 ↘</p> <p>6: 10.4 ↓</p> <p>7: *10.9 →</p> <p>8: 10.4 ↓</p> <p>9: 10.3 ↖</p> <p>10: 10.2 →</p>		
Serie 100.0			
Total 341.0			

<p>Ligg</p> 	<p>Stå</p> 	
<p>1: 10.2 →</p> <p>2: *10.8 ←</p> <p>3: 10.0 →</p> <p>4: *10.8 →</p> <p>5: *10.7 ↓</p>	<p>1: 10.2 ↘</p> <p>2: 10.3 ↓</p> <p>3: 9.5 ↙</p> <p>4: *10.6 ↗</p> <p>5: 10.2 ↖</p>	
Serie 50.0	Serie 49.0	
Total 50.0	Total 99.0	

<p>Kne</p> 	<p>Grunnlag</p> 	
<p>1: *10.7 ↘</p> <p>2: 10.4 ↗</p> <p>3: *10.8 ↓</p> <p>4: *10.7 ↗</p> <p>5: *10.9 →</p>	<p>1: 10.2 ←</p> <p>2: 10.1 ↖</p> <p>3: *10.9 ↘</p> <p>4: 9.6 ↗</p> <p>5: 10.3 ↖</p> <p>6: *10.6 ↓</p> <p>7: 10.3 ↗</p> <p>8: *10.8 ↓</p> <p>9: *10.5 ↓</p> <p>10: 10.1 →</p>	
Serie 50.0	Serie 99.0	
Total 149.0	Total 248.0	

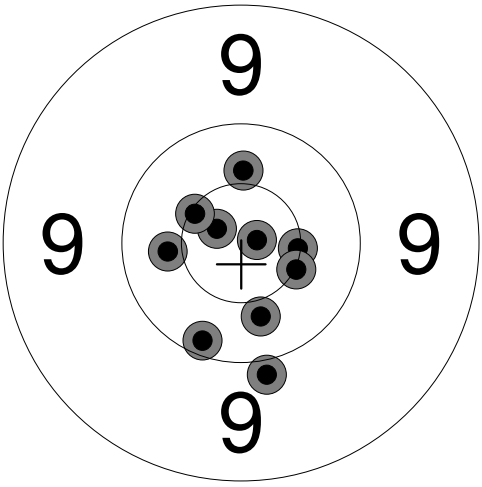
<p>Finale</p> 		
<p>1: *10.8 ↘</p> <p>2: *10.9 →</p> <p>3: 10.1 ↓</p> <p>4: 10.4 ↓</p> <p>5: *10.6 →</p> <p>6: *10.6 ↘</p> <p>7: 10.4 ↑</p> <p>8: *10.5 →</p> <p>9: 10.4 ←</p> <p>10: 9.9 ↓</p>		
Serie 99.0		
Total 347.0		

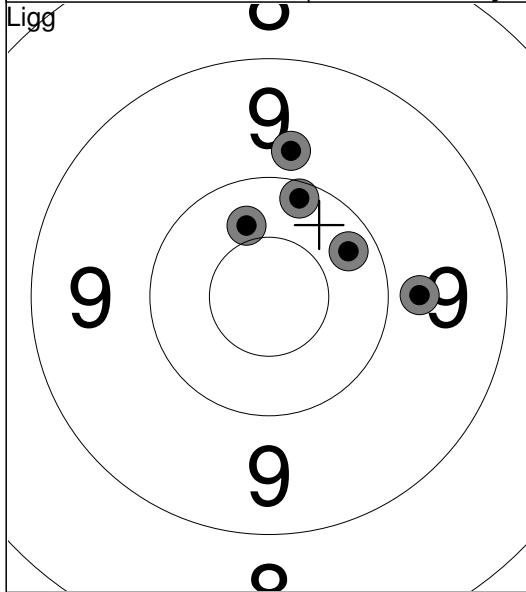

1:	10.2 ↗
2:	9.8 ↗
3:	9.8 →
4:	10.4 ↗
5:	10.3 ↗
Serie 48.0	
Total 48.0	

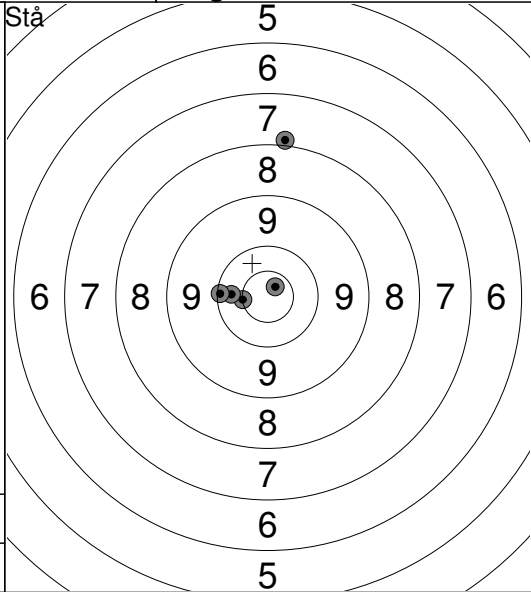

1:	7.9 ↗
2:	*10.8 ↗
3:	*10.5 ←
4:	10.3 ←
5:	10.1 ←
Serie 47.0	
Total 95.0	

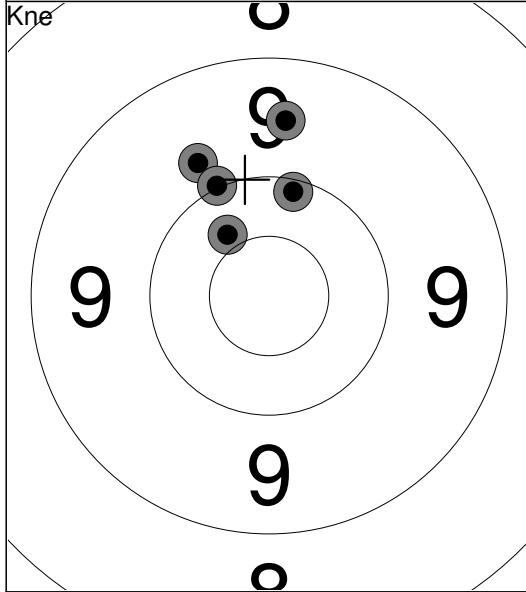

1:	9.8 ↘
2:	10.0 ↗
3:	10.4 ↘
4:	9.5 ↗
5:	10.1 ↗
Serie 48.0	
Total 143.0	

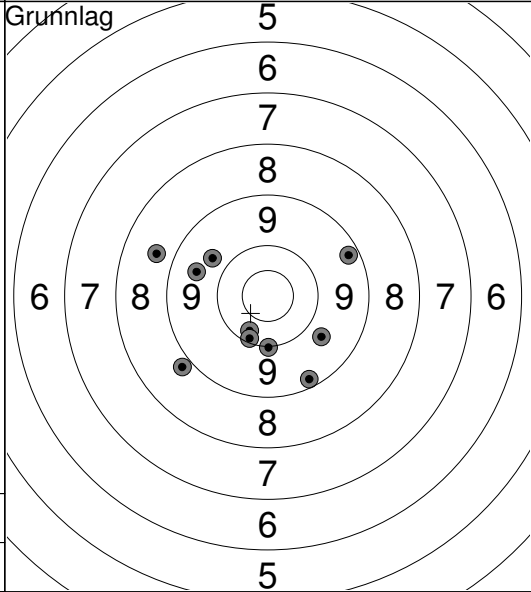

1:	8.7 ←
2:	9.5 ←
3:	9.7 ↘
4:	8.8 ↘
5:	9.2 ↓
6:	10.3 ↓
7:	9.2 →
8:	10.0 ↓
9:	10.1 ↓
10:	9.7 ↘
Serie 91.0	
Total 234.0	

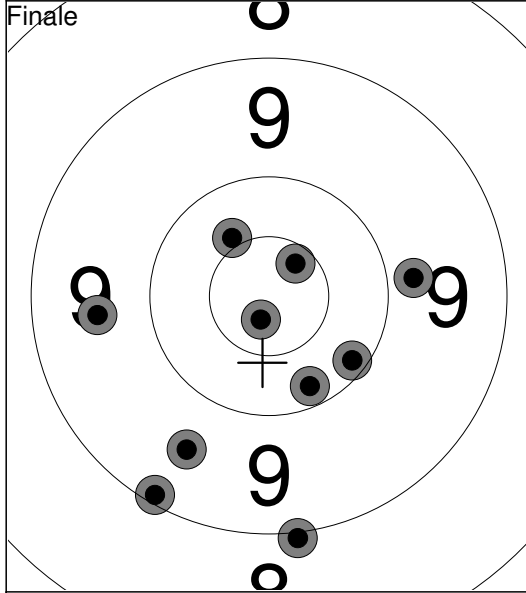

1:	9.8 →
2:	*10.7 ↗
3:	10.1 ↘
4:	*10.8 ↓
5:	9.6 ←
6:	9.6 ↘
7:	10.2 ↓
8:	9.0 ↓
9:	9.1 ↘
10:	*10.5 ↗
Serie 95.0	
Total 329.0	

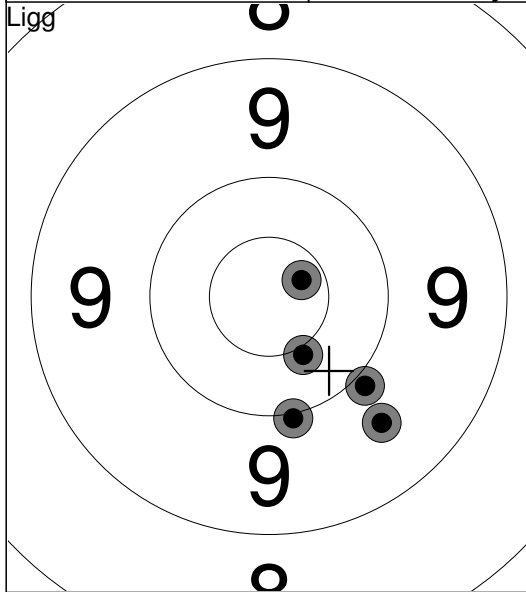

1:	9.6 ↘
2:	*10.5 ↘
3:	10.0 ↘
4:	9.9 ↘
5:	*10.7 ↗
Serie 48.0	
Total 48.0	

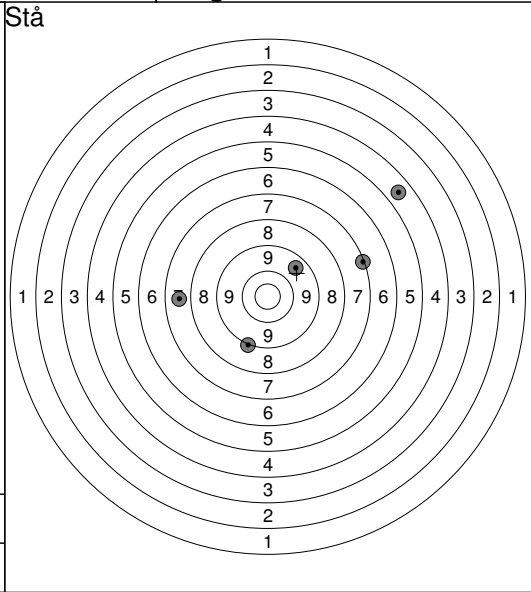

1:	9.0 ↘
2:	7.1 →
3:	9.5 ↗
4:	4.5 ↗
5:	7.6 ←
Serie 36.0	
Total 84.0	

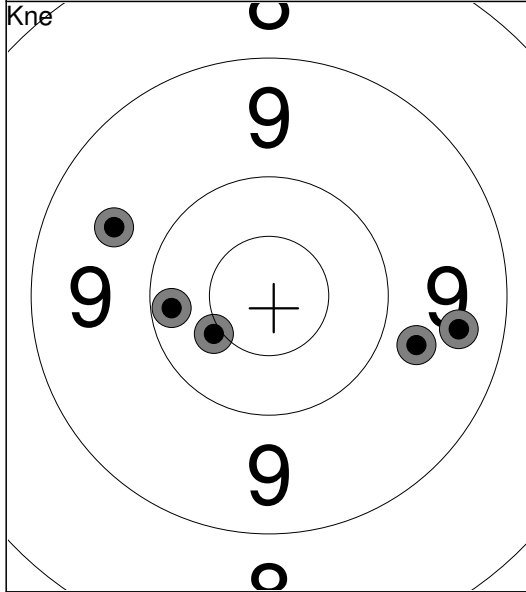

1:	10.2 ←
2:	9.4 →
3:	9.6 ←
4:	*10.5 ↘
5:	9.7 →
Serie 47.0	
Total 131.0	

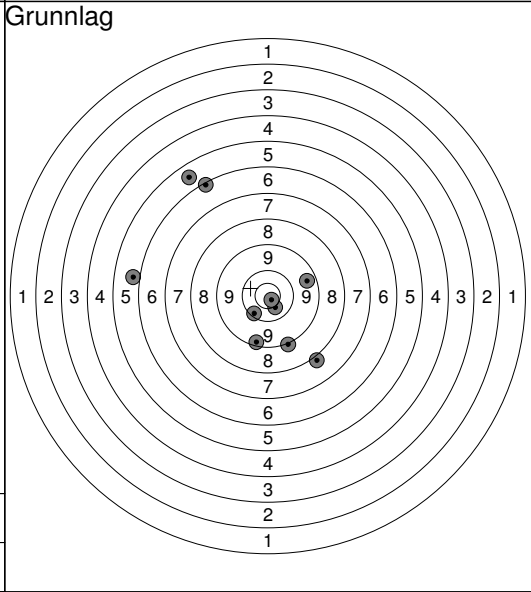

1:	5.7 ←
2:	*10.5 ↘
3:	6.1 ↗
4:	5.5 ↗
5:	*10.8 ↘
6:	9.4 →
7:	10.2 ↘
8:	9.0 ↘
9:	9.2 ↘
10:	7.9 ↘
Serie 80.0	
Total 211.0	

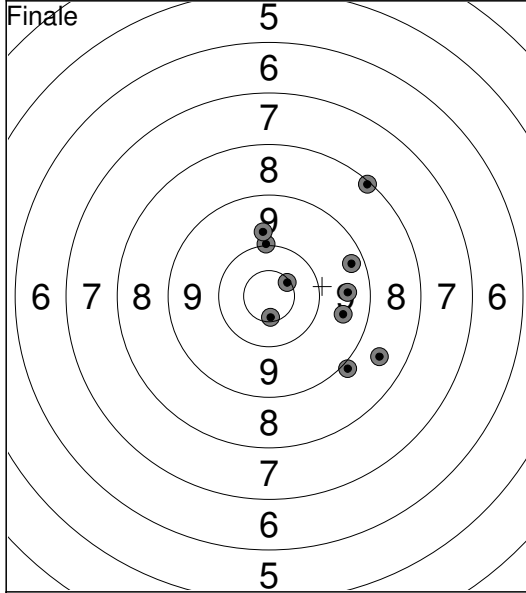

1:	10.0 ↑
2:	9.3 →
3:	9.8 ↑
4:	8.9 ↘
5:	*10.6 ↗
6:	9.5 →
7:	8.5 ↘
8:	9.5 →
9:	8.1 ↗
10:	*10.6 ↘
Serie 90.0	
Total 301.0	

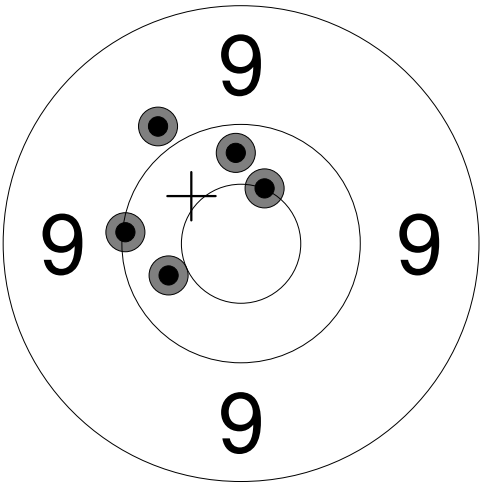
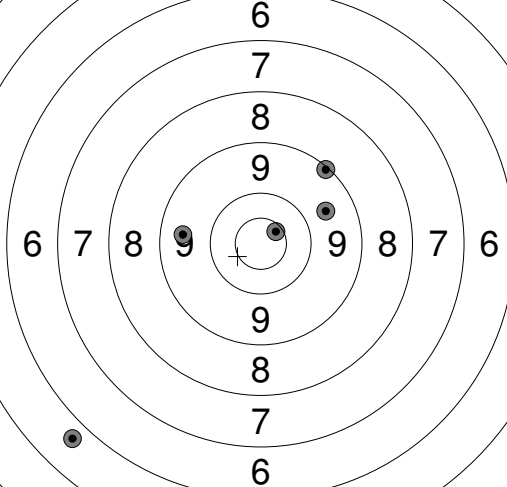
<p>Ligg</p> 	<p>Stå</p> 	<p>1: 5.7 ↙ 2: *10.7 ↗ 3: 9.6 → 4: 9.1 ↗ 5: 9.5 ←</p>
<p>Serie 49.0</p>	<p>Serie 42.0</p>	
<p>Total 49.0</p>	<p>Total 91.0</p>	

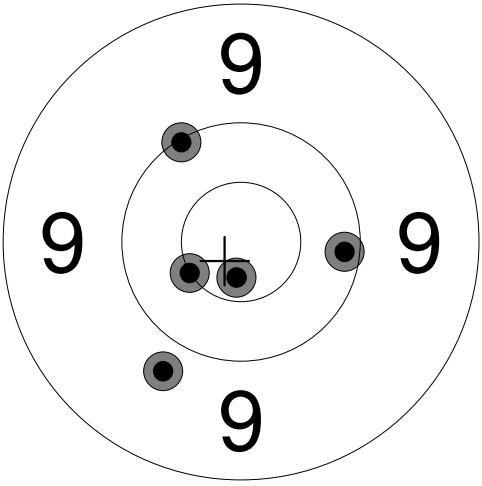
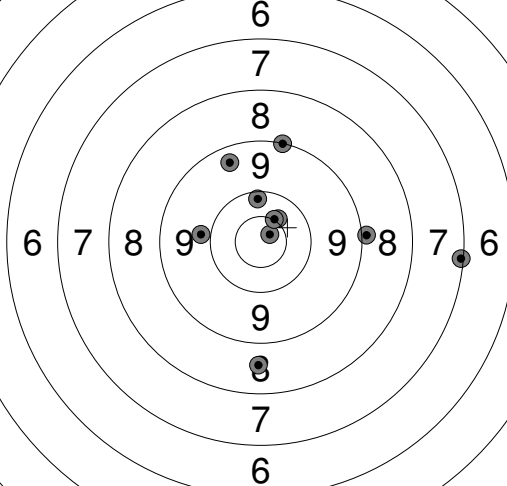
<p>Kne</p> 	<p>Grunnlag</p> 	<p>1: 9.8 ↙ 2: 10.1 ↖ 3: *10.5 ↙ 4: 10.2 → 5: *10.7 ↓</p>
<p>Serie 49.0</p>	<p>Serie 90.0</p>	
<p>Total 140.0</p>	<p>Total 230.0</p>	

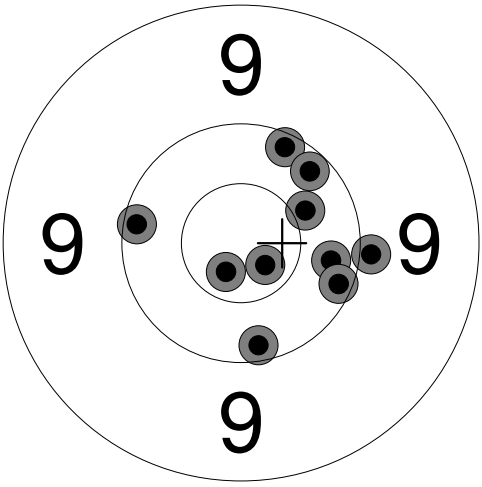
<p>Finale</p> 	<p>1: 10.1 ← 2: 10.3 → 3: *10.8 ↙ 4: 10.4 → 5: 9.9 → 6: 10.1 ↗ 7: *10.8 ↘ 8: 10.2 ↗ 9: 10.2 ↓ 10: 10.1 →</p>	
<p>Serie 99.0</p>		
<p>Total 329.0</p>		

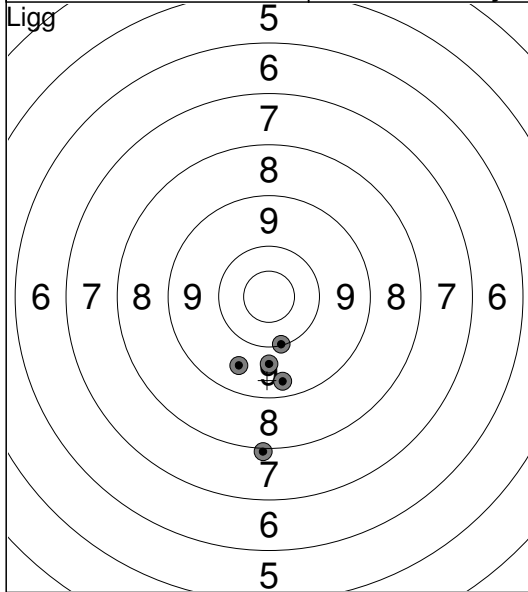

1:	9.6	↘
2:	10.1	↓
3:	8.0	↓
4:	9.3	↓
5:	9.7	↓
Serie		45.0
Total		45.0

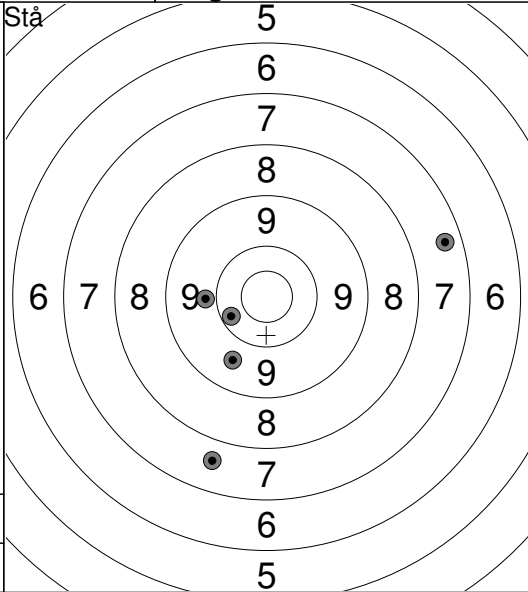

1:	9.6	↘
2:	7.4	→
3:	9.8	←
4:	10.2	↙
5:	7.6	↓
Serie		42.0
Total		87.0

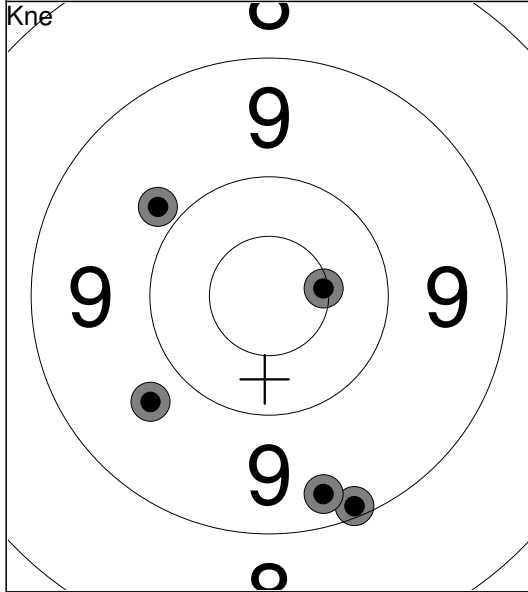

1:	*10.6	→
2:	9.7	↙
3:	9.1	↓
4:	9.3	↓
5:	9.8	↖
Serie		46.0
Total		133.0

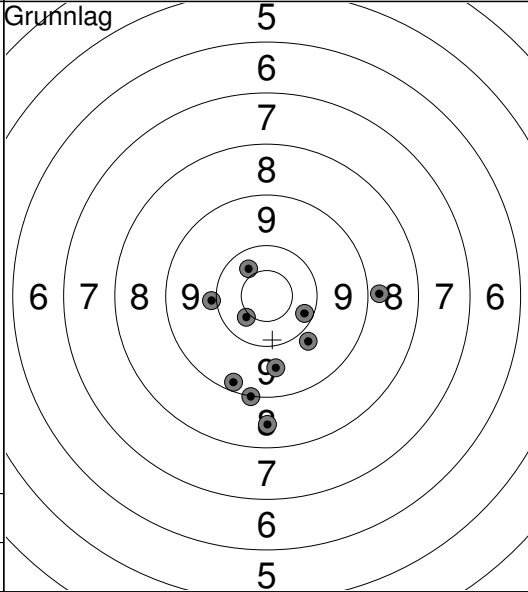

1:	9.8	↘
2:	8.5	↓
3:	10.2	→
4:	10.4	↙
5:	10.4	↖
6:	9.0	↓
7:	8.8	→
8:	9.2	↓
9:	9.9	←
10:	9.6	↓
Serie		91.0
Total		224.0

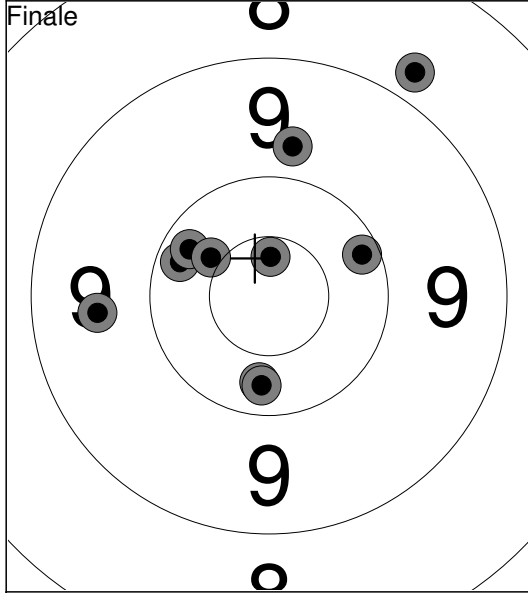

1:	*10.7	↑
2:	10.2	↙
3:	10.2	→
4:	10.3	↙
5:	9.8	↑
6:	8.8	↗
7:	10.3	↓
8:	10.3	↓
9:	10.4	↙
10:	9.6	←
Serie		96.0
Total		320.0

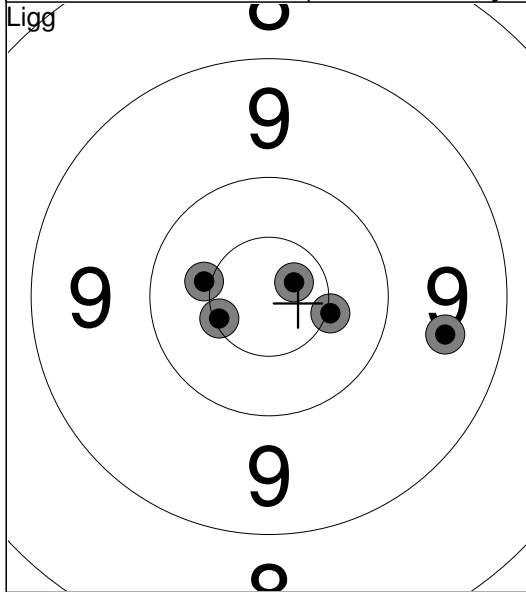

Stå

1:	9.5	→
2:	*10.5	↙
3:	*10.5	→
4:	*10.6	↙
5:	*10.8	↗

Serie	49.0
Total	49.0

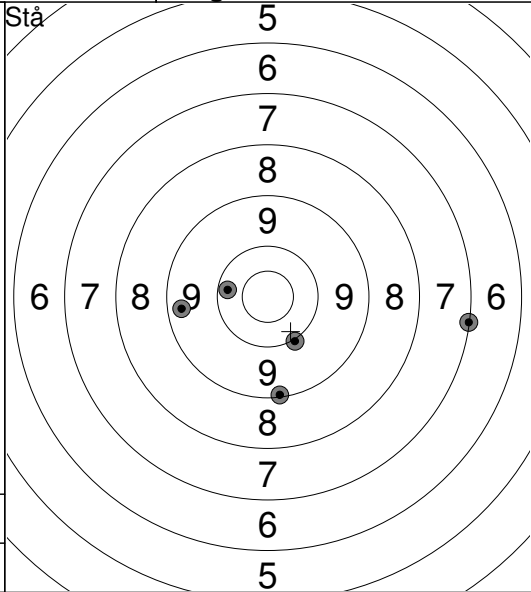

1:	10.0	↘
2:	9.3	←
3:	10.2	↙
4:	7.0	→
5:	9.1	↓

Serie	45.0
Total	94.0

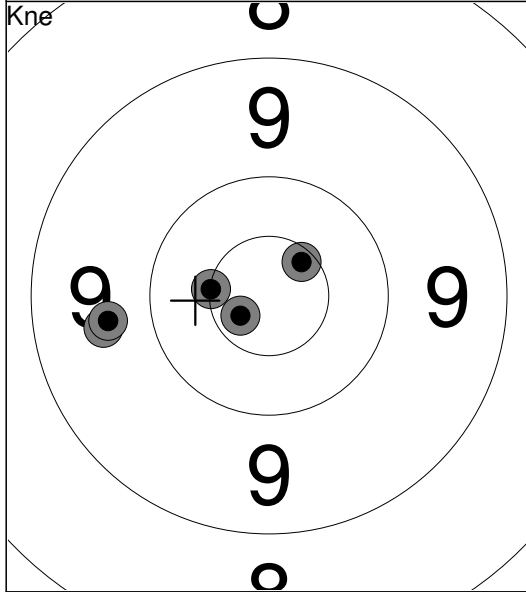

Grunnlag

1:	9.6	←
2:	9.7	←
3:	*10.6	↗
4:	*10.5	↙
5:	*10.7	↙

Serie	48.0
Total	142.0

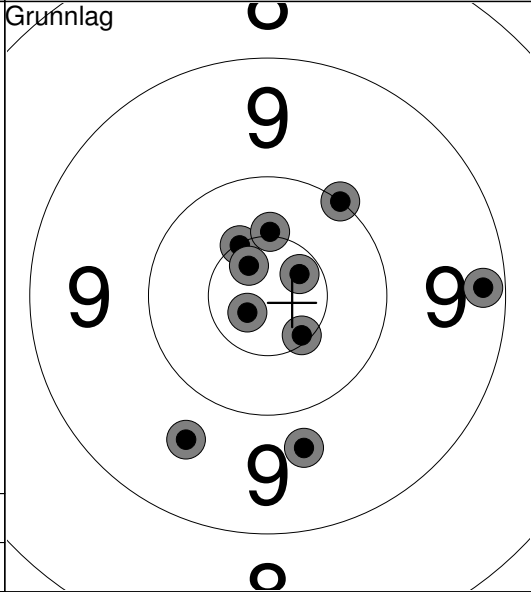

1:	10.0	↗
2:	9.7	↓
3:	9.2	→
4:	*10.5	↖
5:	*10.7	↗
6:	9.6	↓
7:	*10.6	↘
8:	*10.7	↖
9:	*10.8	↙
10:	*10.5	↑

Serie	97.0
Total	239.0

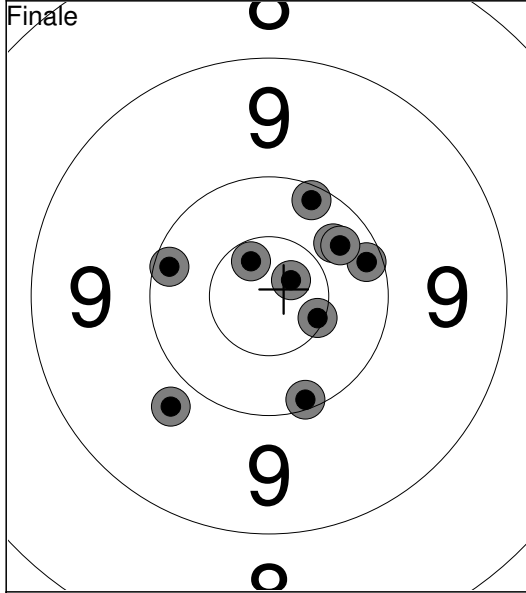

1:	10.2	↗
2:	*10.7	↖
3:	10.3	↗
4:	*10.6	→
5:	10.2	→
6:	*10.8	↗
7:	10.1	↓
8:	10.3	↗
9:	10.2	↙
10:	9.8	↙

Serie	99.0
Total	338.0

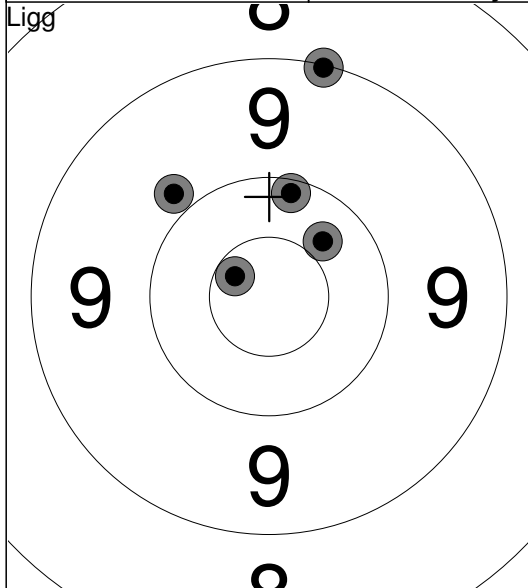

1:	9.9 ↖
2:	10.1 ↑
3:	9.1 ↑
4:	*10.7 ↖
5:	10.4 ↗
Serie 48.0	
Total 48.0	

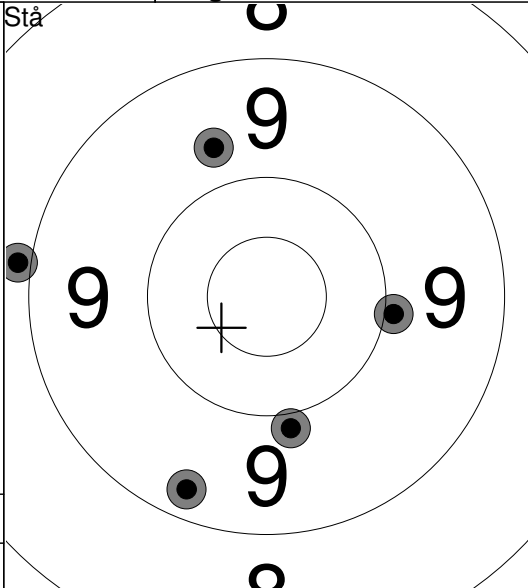

1:	9.7 ↑
2:	10.0 →
3:	8.9 ←
4:	9.9 ↓
5:	9.3 ↓
Serie 45.0	
Total 93.0	

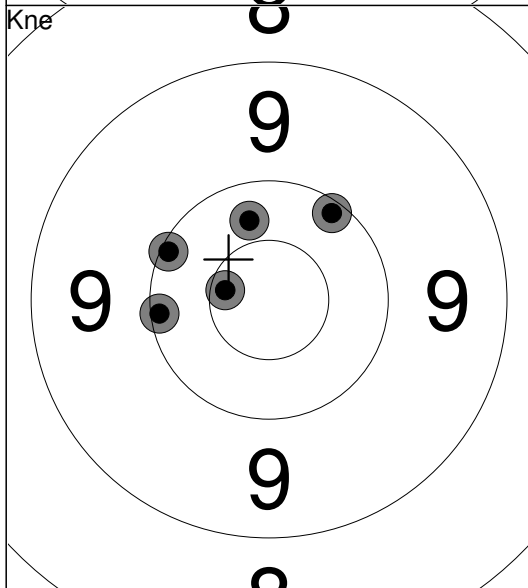

1:	10.3 ↑
2:	10.1 ↗
3:	*10.6 ←
4:	10.1 ↖
5:	10.1 ←
Serie 50.0	
Total 143.0	

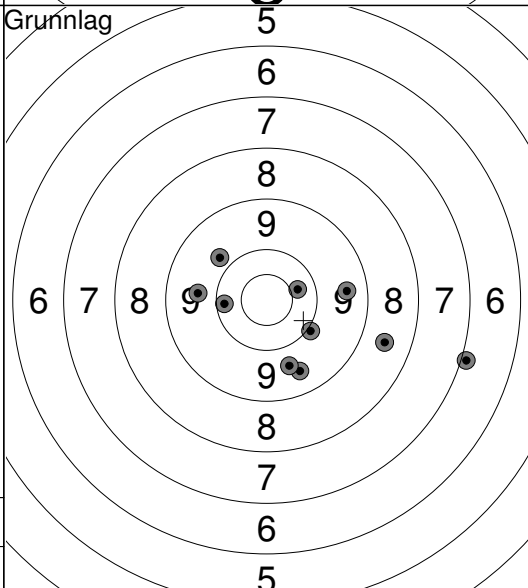

1:	9.5 ↓
2:	6.9 →
3:	9.4 →
4:	9.7 ↓
5:	9.8 ↗
6:	8.6 →
7:	10.4 →
8:	10.0 ↘
9:	9.7 ←
10:	10.2 ←
Serie 89.0	
Total 232.0	

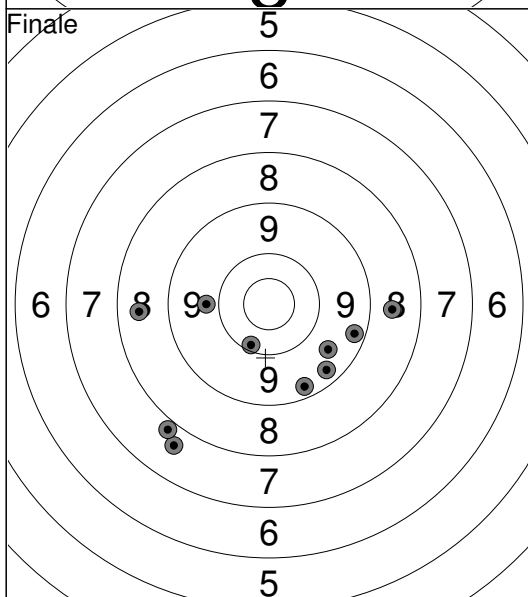

1:	8.6 →
2:	9.3 ↓
3:	10.1 ↓
4:	7.7 ↓
5:	9.6 ↘
6:	9.8 ←
7:	7.8 ↓
8:	9.2 →
9:	9.3 ↓
10:	8.5 ←
Serie 85.0	
Total 317.0	

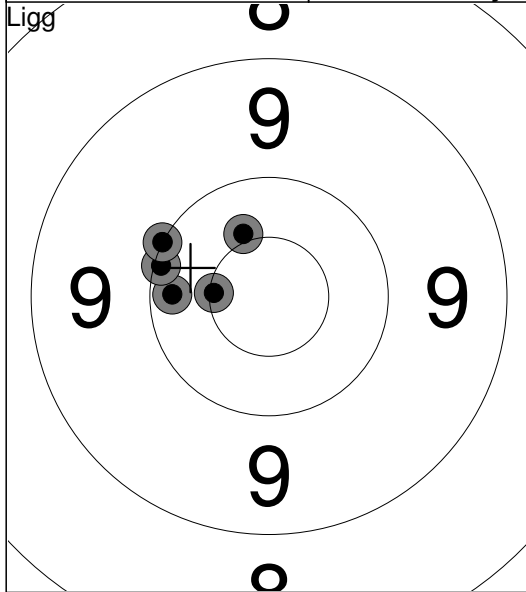

1:	*10.5 ↖
2:	10.2 ←
3:	*10.6 ←
4:	10.1 ←
5:	10.0 ↖
Serie 50.0	
Total 50.0	

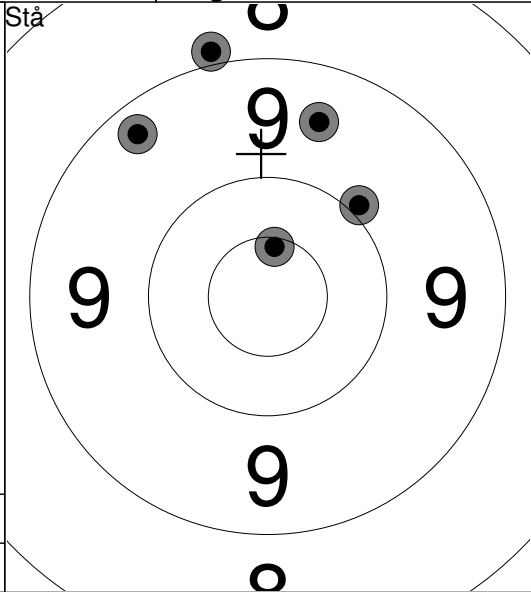

1:	9.3 ↖
2:	9.9 ↗
3:	8.9 ↑
4:	9.5 ↑
5:	*10.6 ↑
Serie 45.0	
Total 95.0	

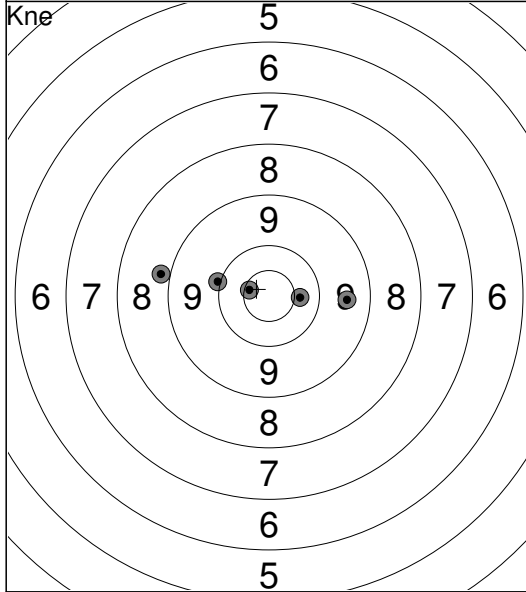

1:	10.0 ←
2:	10.4 →
3:	9.5 →
4:	*10.6 ←
5:	8.9 ←
Serie 47.0	
Total 142.0	

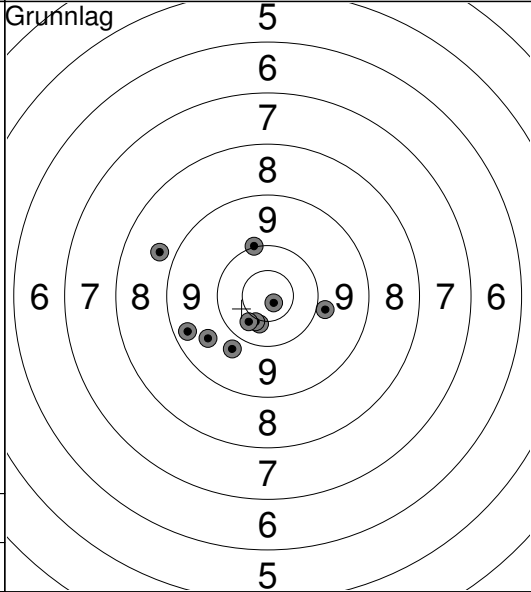

1:	8.7 ←
2:	10.0 ↑
3:	9.9 →
4:	*10.5 ↓
5:	*10.5 ↓
6:	9.3 ←
7:	9.8 ↓
8:	10.4 ↓
9:	9.6 ←
10:	*10.9 ↓
Serie 94.0	
Total 236.0	

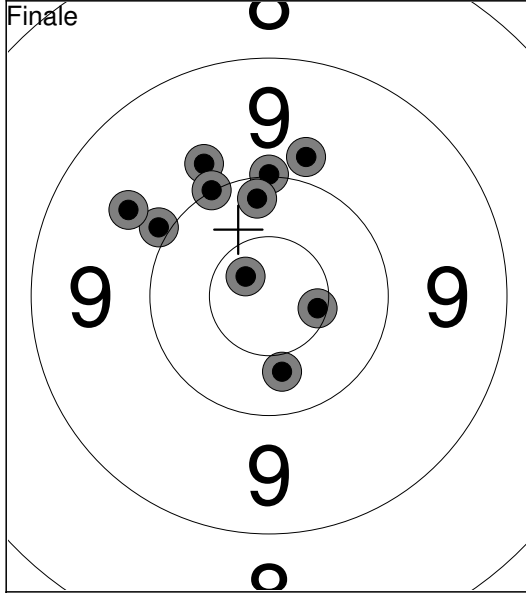

1:	9.8 ↑
2:	*10.6 →
3:	*10.8 ↖
4:	10.0 ↑
5:	10.2 ↑
6:	9.9 ↖
7:	9.8 ↗
8:	9.6 ↖
9:	10.4 ↓
10:	10.0 ↖
Serie 96.0	
Total 332.0	

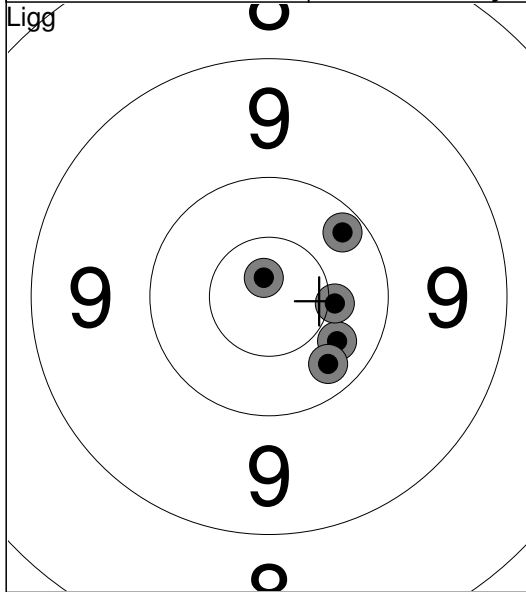

1:	10.3 ↘
2:	10.2 ↗
3:	*10.9 ↗
4:	10.3 ↘
5:	*10.5 →
Serie 50.0	
Total 50.0	

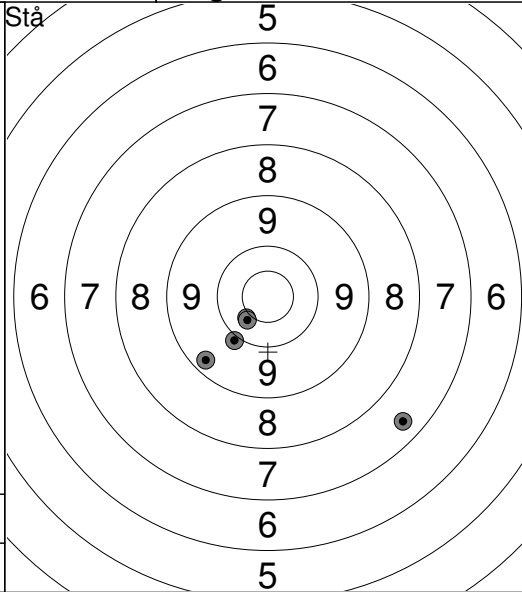

1:	9.3 ↘
2:	10.4 ↘
3:	7.4 ↘
4:	9.9 ↘
5:	10.4 ↘
Serie 45.0	
Total 95.0	

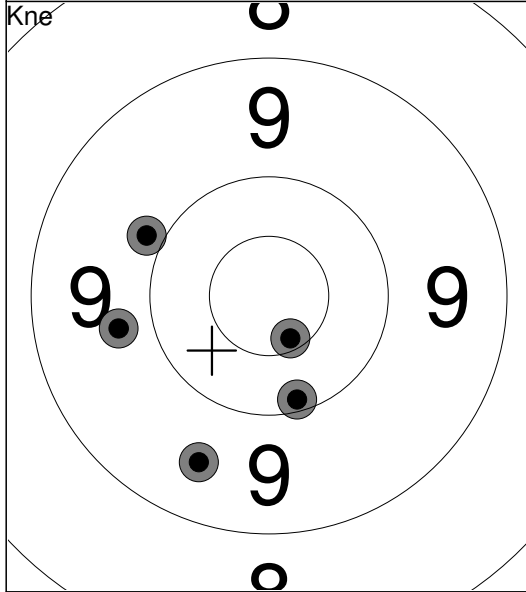

1:	9.9 ↙
2:	9.7 ↙
3:	9.5 ↘
4:	10.1 ↘
5:	*10.6 ↘
Serie 47.0	
Total 142.0	

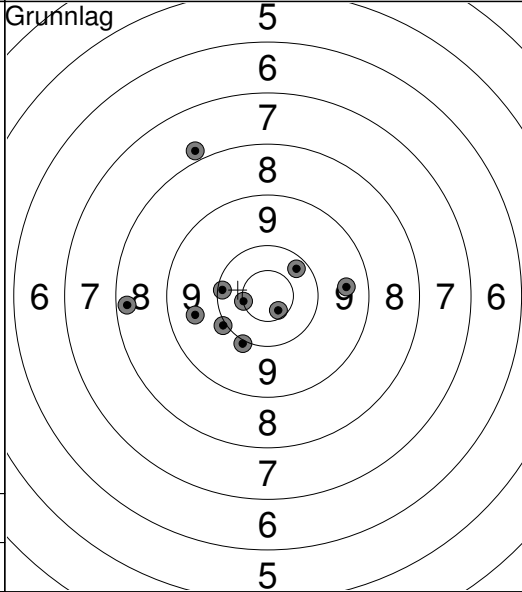

1:	*10.5 ↙
2:	7.8 ↗
3:	9.5 →
4:	10.3 ↗
5:	10.1 ↙
6:	8.3 ↙
7:	*10.7 ↘
8:	10.0 ↘
9:	9.6 ↙
10:	10.0 ↘
Serie 93.0	
Total 235.0	

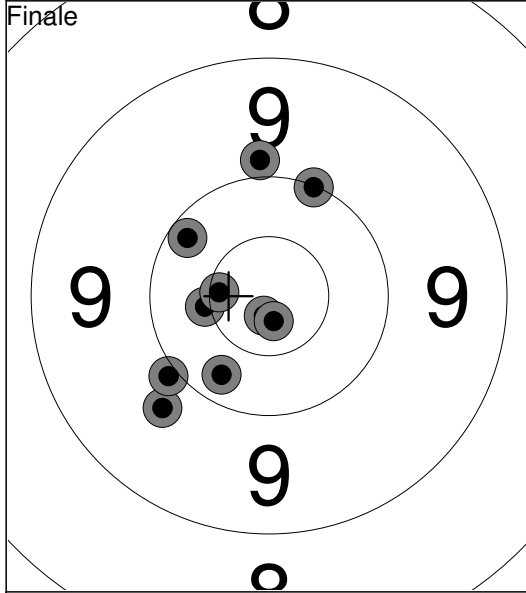

1:	10.0 ↗
2:	*10.9 ↘
3:	9.7 ↘
4:	9.9 ↗
5:	*10.8 ↘
6:	10.2 ↘
7:	10.3 ↘
8:	9.9 ↘
9:	*10.5 ↙
10:	*10.6 ↙
Serie 97.0	
Total 332.0	

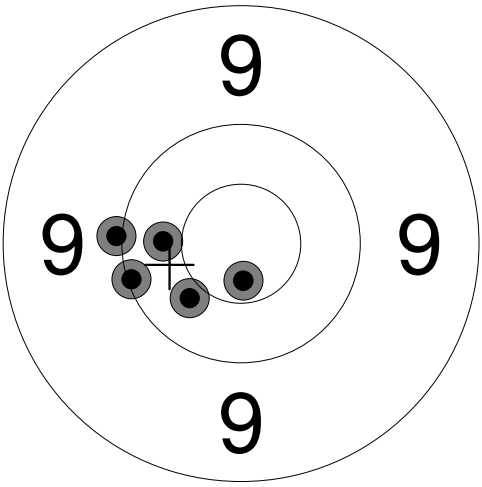
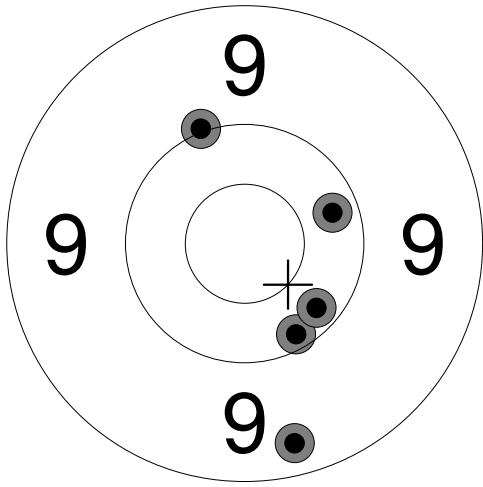
<p>Ligg</p> 	<p>Stå</p> 	
<p>1: 10.4 ↙</p> <p>2: 10.4 ←</p> <p>3: *10.7 ↓</p> <p>4: 10.1 ←</p> <p>5: 10.0 ←</p>	<p>1: 10.0 ↗</p> <p>2: 10.2 →</p> <p>3: 10.2 ↓</p> <p>4: 9.3 ↓</p> <p>5: 10.2 ↓</p>	
Serie 50.0		Serie 49.0
Total 50.0		Total 99.0

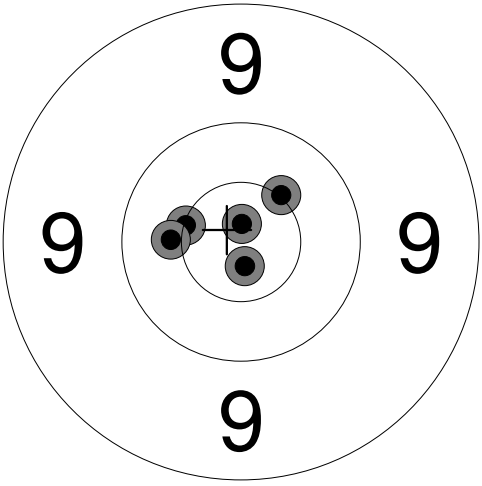
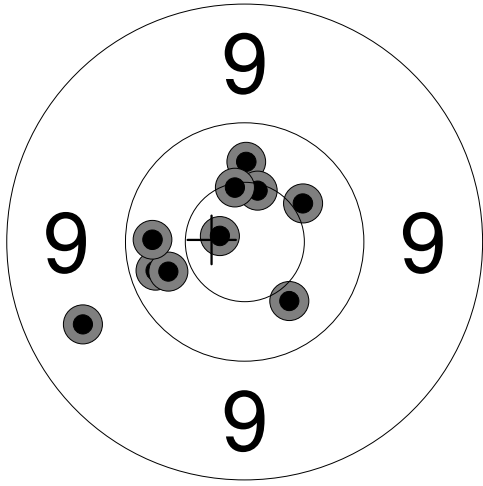
<p>Kne</p> 	<p>Grunnlag</p> 	
<p>1: *10.5 ↗</p> <p>2: *10.8 ↓</p> <p>3: *10.5 ←</p> <p>4: *10.9 ↑</p> <p>5: 10.4 ←</p>	<p>1: 10.4 ↑</p> <p>2: *10.8 ←</p> <p>3: 10.2 ←</p> <p>4: *10.6 ↑</p> <p>5: 10.4 ↗</p> <p>6: 9.5 ←</p> <p>7: *10.6 ↑</p> <p>8: 10.3 ←</p> <p>9: 10.4 ↓</p> <p>10: 10.3 ←</p>	
Serie 50.0		Serie 99.0
Total 149.0		Total 248.0

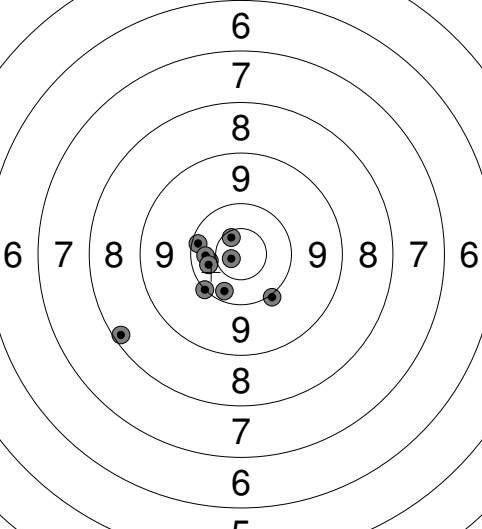
<p>Finale</p> 	<p>1: 10.4 ←</p> <p>2: *10.6 ↗</p> <p>3: 10.2 ←</p> <p>4: 10.0 ↙</p> <p>5: 8.2 ↙</p> <p>6: 10.2 ↓</p> <p>7: 10.3 ←</p> <p>8: 10.0 ↓</p> <p>9: 10.4 ←</p> <p>10: *10.8 ←</p>	
Serie 98.0		
Total 346.0		