

1:	10.3 ↘
2:	9.2 ↙
3:	9.8 ↓
4:	10.4 →
5:	10.4 →
<b>Serie 48.0</b>	
<b>Total 48.0</b>	

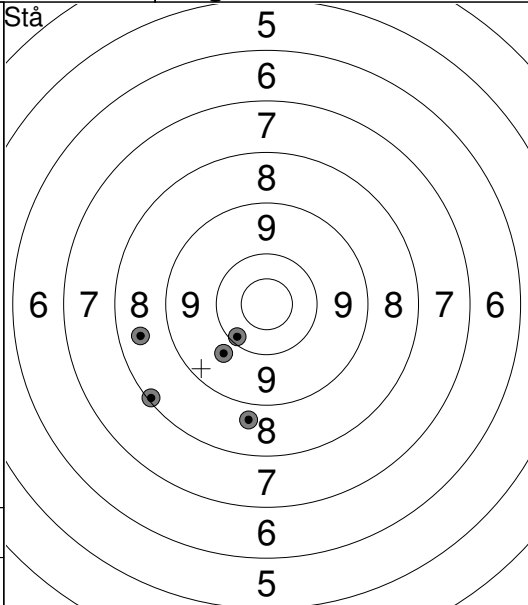

1:	8.1 ↙
2:	9.7 ↙
3:	8.7 ↓
4:	8.5 ←
5:	10.2 ↙
<b>Serie 43.0</b>	
<b>Total 91.0</b>	

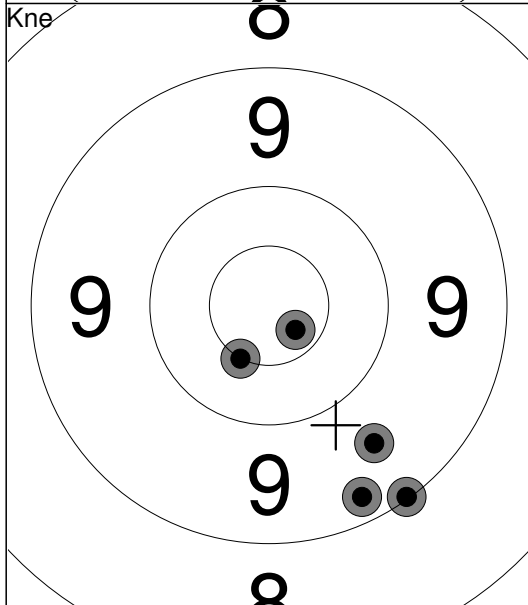

1:	*10.5 ↘
2:	9.2 ↓
3:	9.1 ↘
4:	9.6 ↓
5:	*10.7 ↘
<b>Serie 47.0</b>	
<b>Total 138.0</b>	

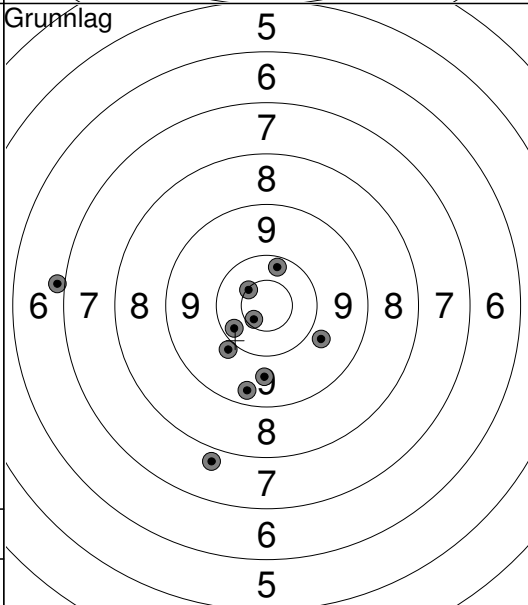

1:	9.9 ↙
2:	6.9 ←
3:	10.2 ↑
4:	*10.6 ↘
5:	7.8 ↓
6:	9.6 ↓
7:	9.8 →
8:	*10.7 ↘
9:	9.3 ↓
10:	10.3 ↙
<b>Serie 89.0</b>	
<b>Total 227.0</b>	

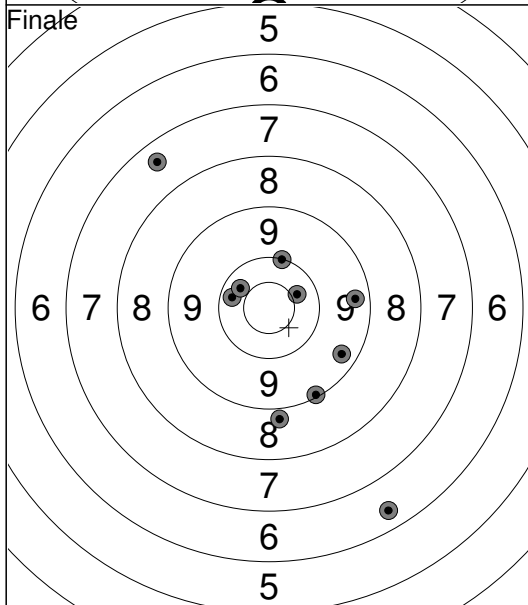

1:	9.3 →
2:	10.0 ↑
3:	7.4 ↗
4:	9.1 ↓
5:	6.4 ↓
6:	10.4 →
7:	10.3 ←
8:	8.8 ↓
9:	9.3 ↘
10:	10.3 ↖
<b>Serie 88.0</b>	
<b>Total 315.0</b>	

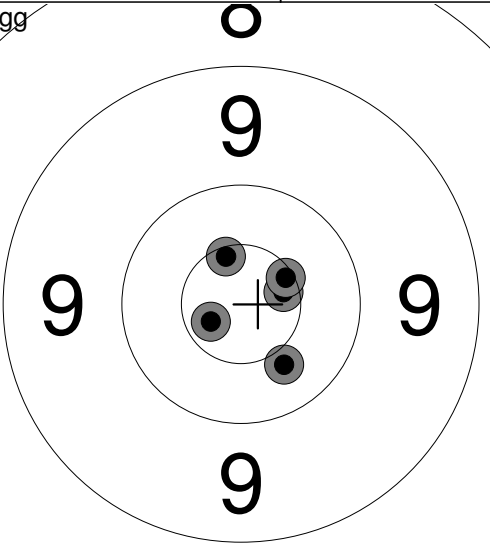
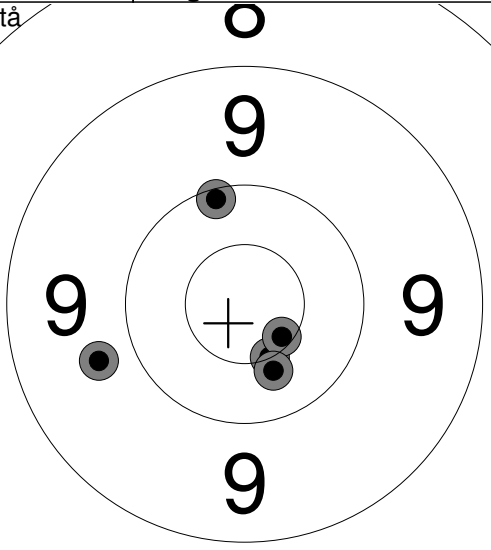
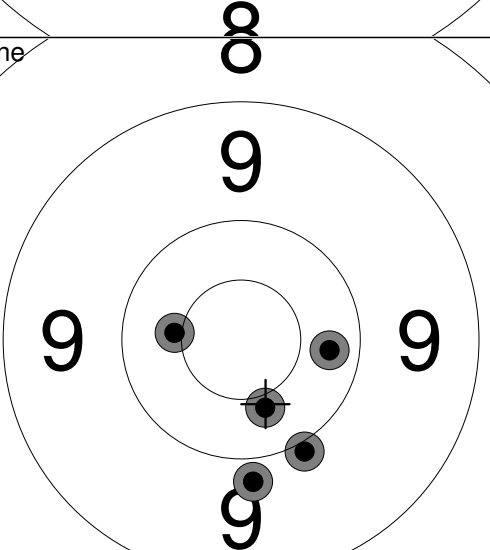
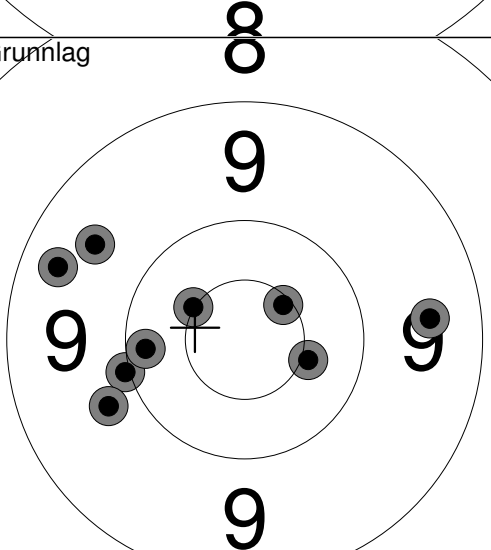
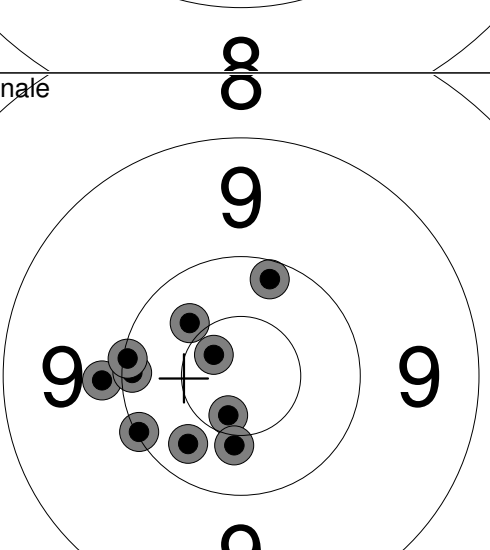
Lag	Skive	Torfinn Gaustad	
1	3		
200m	Trøgstad	V55	
01.06.2016	Kristian Garsruds minnepokal	Trøgstad SKL	
Ligg		Stå	
	1: *10.6 ↗ 2: *10.7 → 3: *10.7 ↙ 4: 10.4 ↓ 5: *10.6 ↗		1: *10.5 ↓ 2: 10.1 ↑ 3: 9.7 ← 4: *10.6 ↓ 5: 10.4 ↓
	Serie 50.0		Serie 49.0
	Total 50.0		Total 99.0
Kne		Grunnlag	
	1: 9.9 ↓ 2: *10.5 ← 3: 10.3 → 4: 9.8 ↓ 5: 10.4 ↓		1: 9.5 → 2: 10.0 ← 3: 9.3 ← 4: 9.8 ← 5: 9.5 ← 6: *10.5 ↙ 7: 10.2 ← 8: *10.5 → 9: *10.6 ↗
	Serie 48.0		Serie 86.0
	Total 147.0		Total 233.0
Finale			
	1: *10.7 ↙ 2: 10.4 ↙ 3: *10.7 ↓ 4: 10.1 ↙ 5: 10.4 ↓ 6: 9.9 ← 7: 10.1 ← 8: 10.1 ← 9: 10.3 ↙ 10: 10.2 ↑		
	Serie 99.0		
	Total 332.0		

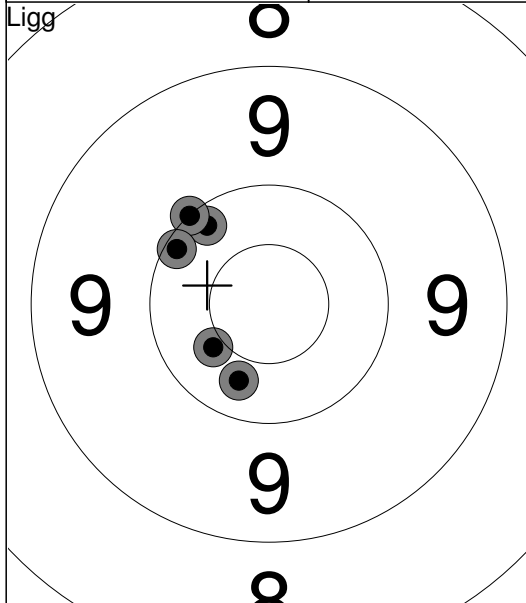

1:	10.4 ↙
2:	10.2 ↖
3:	10.0 ↗
4:	10.1 ↘
5:	10.3 ↓
Serie 50.0	
Total 50.0	

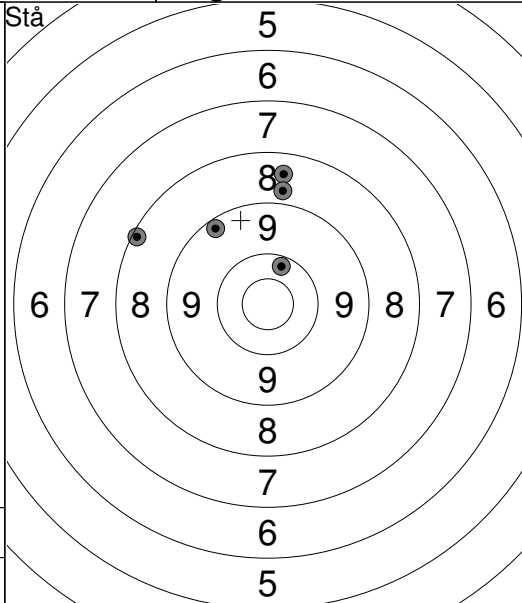

1:	8.5 ↑
2:	9.2 ↖
3:	10.2 ↑
4:	8.1 ↙
5:	8.8 ↑
Serie 43.0	
Total 93.0	

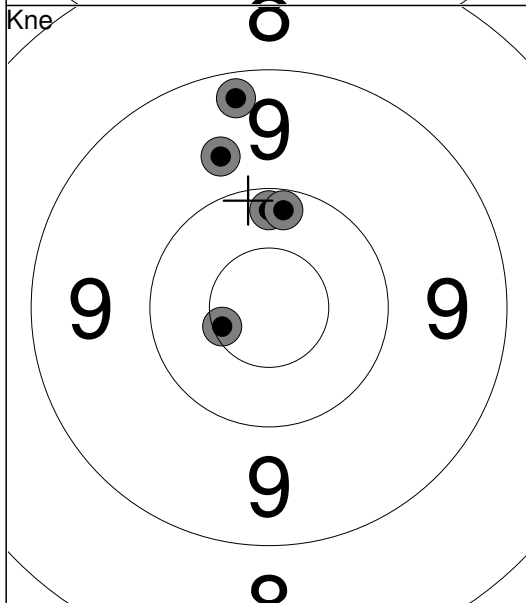

1:	10.2 ↑
2:	9.2 ↑
3:	10.2 ↑
4:	*10.6 ↙
5:	9.7 ↑
Serie 48.0	
Total 141.0	

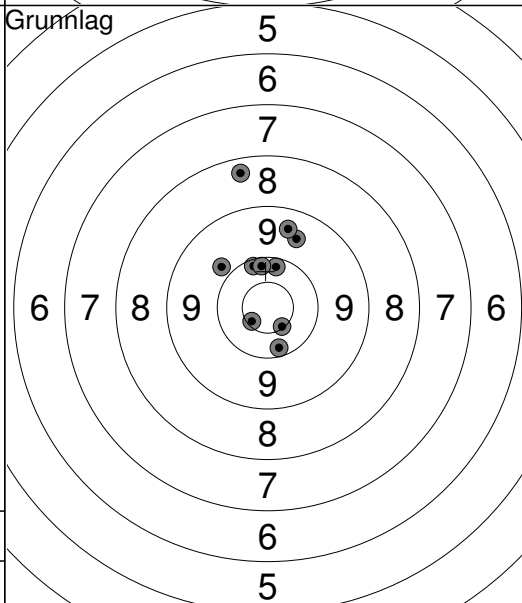

1:	9.6 ↑
2:	8.3 ↑
3:	*10.6 ↘
4:	10.2 ↑
5:	9.4 ↑
6:	9.8 ↖
7:	10.2 ↑
8:	10.2 ↑
9:	*10.6 ↙
10:	10.2 ↓
Serie 95.0	
Total 236.0	

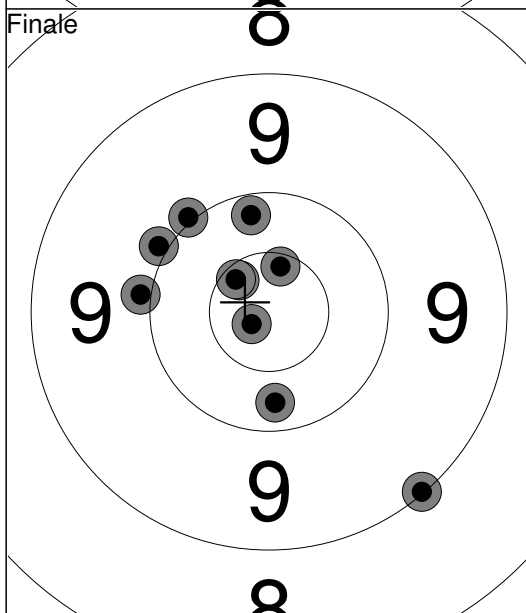

1:	10.2 ↑
2:	*10.7 ↖
3:	*10.9 ↘
4:	9.0 ↓
5:	10.3 ↓
6:	*10.6 ↑
7:	9.9 ←
8:	*10.6 ↖
9:	10.0 ↖
10:	10.0 ↖
Serie 98.0	
Total 334.0	

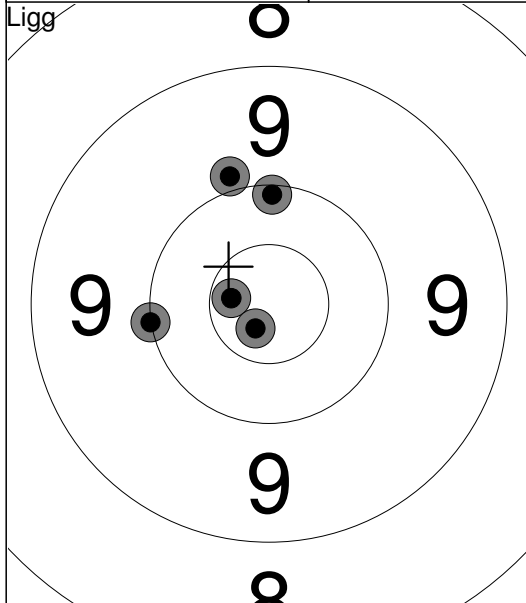

1:	*10.7	←
2:	9.9	↑
3:	10.0	←
4:	10.1	↑
5:	*10.8	↓
Serie		49.0
Total		49.0

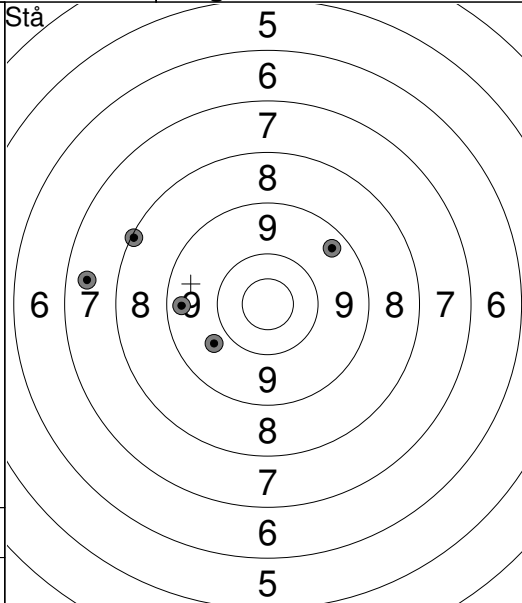

1:	7.4	←
2:	9.7	↙
3:	9.3	↗
4:	9.3	←
5:	8.1	↖
Serie		42.0
Total		91.0

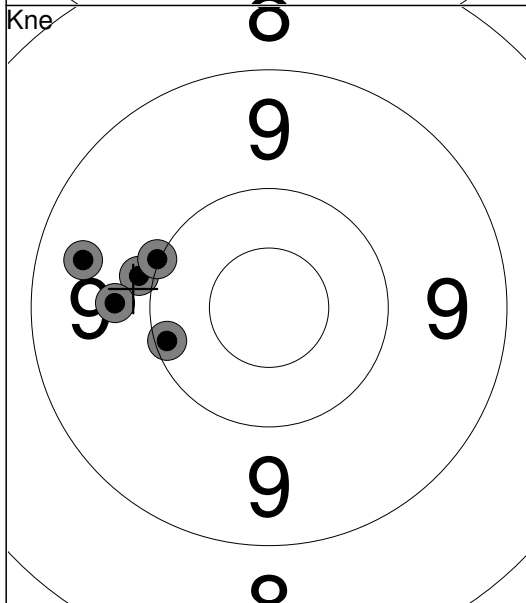

1:	9.9	←
2:	10.0	↖
3:	9.4	←
4:	9.7	←
5:	10.1	←
Serie		47.0
Total		138.0

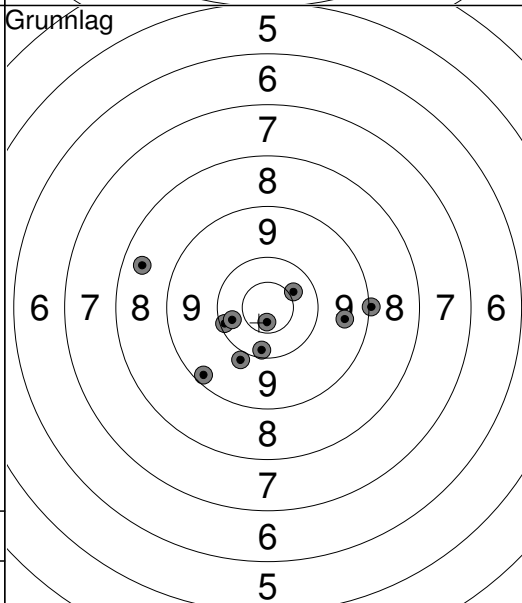

1:	*10.8	↓
2:	10.4	↗
3:	8.4	←
4:	9.9	↓
5:	9.5	→
6:	9.0	→
7:	10.1	←
8:	10.3	←
9:	10.2	↓
10:	9.2	↙
Serie		94.0
Total		232.0

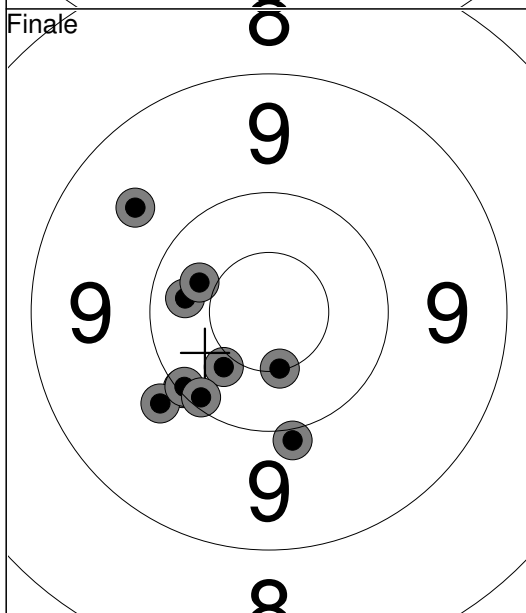

1:	10.1	↙
2:	10.3	←
3:	9.6	↗
4:	10.4	←
5:	9.8	↙
6:	10.1	↙
7:	10.4	↙
8:	10.1	↙
9:	*10.5	↓
10:	9.9	↓
Serie		97.0
Total		329.0

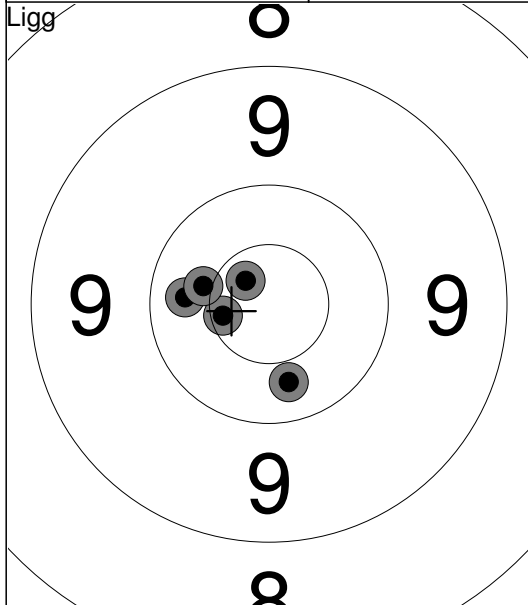

1:	*10.6
2:	*10.8
3:	10.3
4:	10.4
5:	*10.5
Serie 50.0	
Total 50.0	

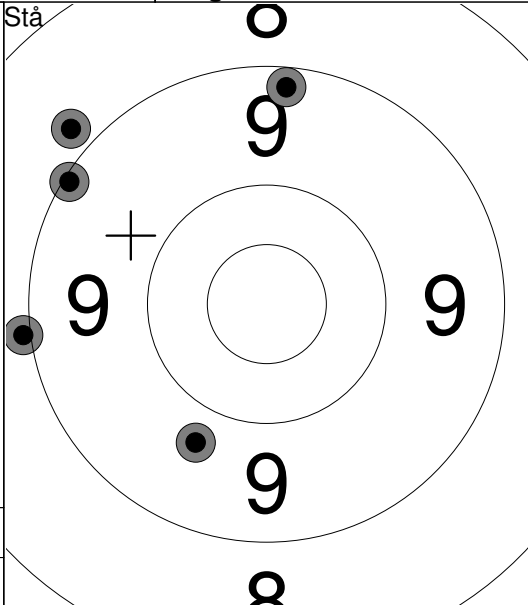

1:	9.2	↑
2:	8.8	↖
3:	9.1	↖
4:	9.0	←
5:	9.7	↓
Serie 44.0		
Total 94.0		

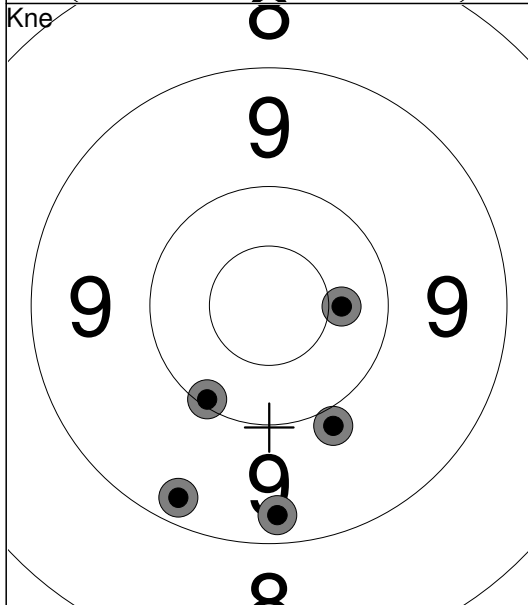

1:	10.4	→
2:	9.3	↓
3:	9.2	↙
4:	9.9	↓
5:	10.1	↙
Serie 47.0		
Total 141.0		

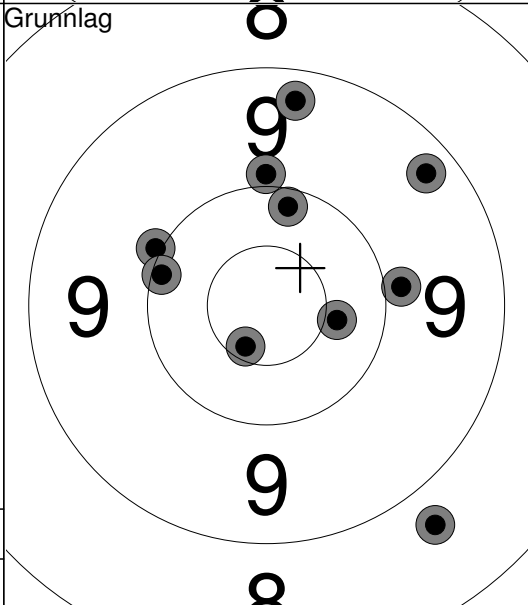

1:	10.0	↖
2:	9.3	↑
3:	9.3	↗
4:	8.7	↘
5:	*10.6	↙
6:	10.1	←
7:	9.9	↑
8:	10.2	↑
9:	9.9	→
10:	10.4	→
Serie 94.0		
Total 235.0		

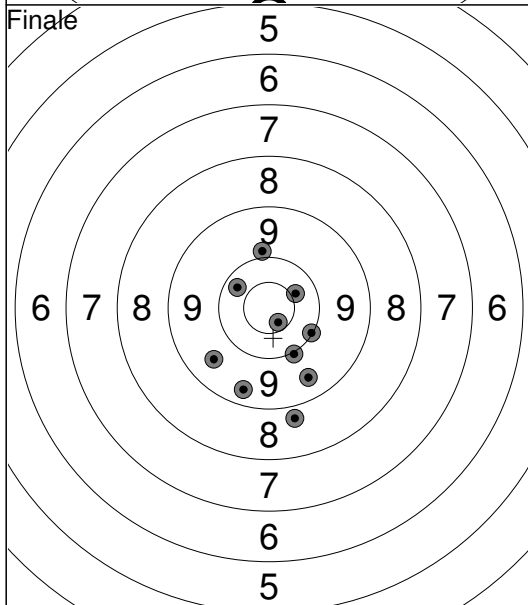

1:	9.9	↑
2:	10.1	→
3:	*10.7	↘
4:	10.4	↗
5:	10.3	↖
6:	10.0	↓
7:	9.5	↓
8:	8.8	↓
9:	9.3	↓
10:	9.5	↙
Serie 94.0		
Total 329.0		

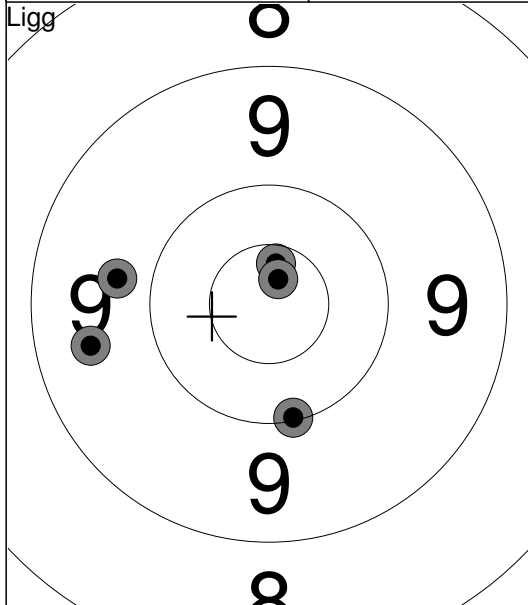

1:	9.5	←
2:	9.7	←
3:	10.1	↓
4:	*10.7	↑
5:	*10.8	↑
Serie		48.0
Total		48.0

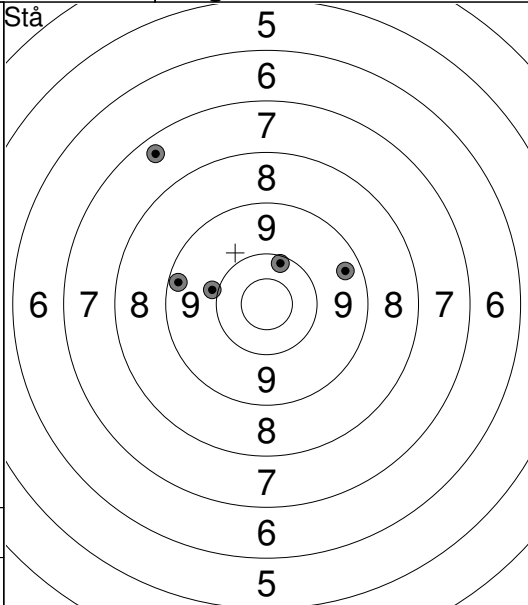

1:	10.2	↑
2:	9.9	←
3:	9.2	←
4:	9.3	➤
5:	7.3	↖
Serie		44.0
Total		92.0

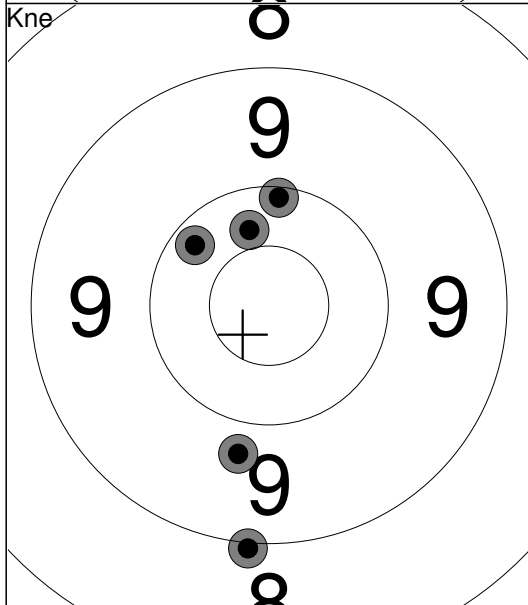

1:	10.2	↖
2:	9.8	↓
3:	10.1	↑
4:	9.0	↓
5:	10.4	↑
Serie		48.0
Total		140.0

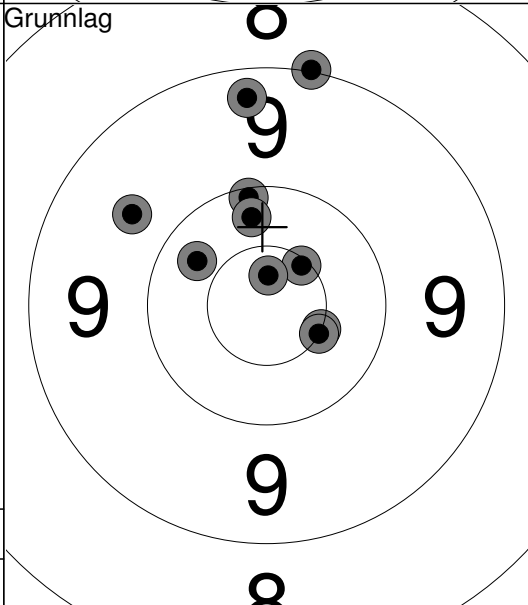

1:	10.3	↖
2:	*10.5	➤
3:	9.7	↖
4:	*10.6	↗
5:	9.3	↑
6:	9.0	↑
7:	10.1	↑
8:	*10.8	↑
9:	10.3	↑
10:	*10.5	➤
Serie		97.0
Total		237.0

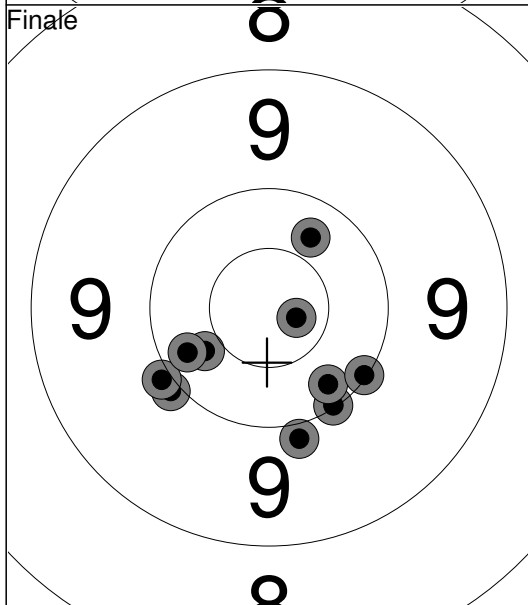

1:	10.4	↙
2:	9.9	↓
3:	9.9	↙
4:	9.9	↙
5:	10.0	↓
6:	10.2	↓
7:	*10.8	➤
8:	10.3	↗
9:	10.2	↙
10:	10.1	↘
Serie		97.0
Total		334.0

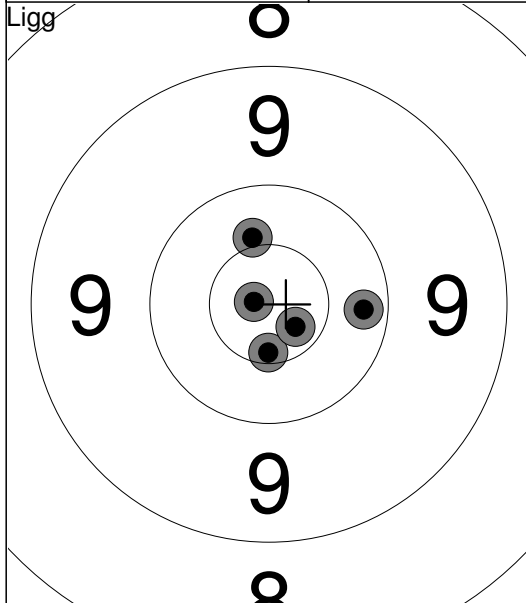

1:	*10.9 ←
2:	10.2 →
3:	*10.6 ↓
4:	*10.7 ↘
5:	*10.5 ↑
Serie 50.0	
Total 50.0	

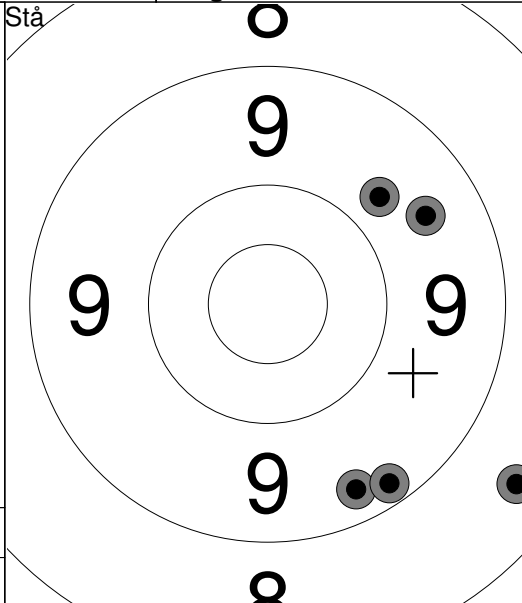

1:	9.5 ↗
2:	9.7 ↗
3:	9.3 ↓
4:	9.2 ↓
5:	8.4 ↘
Serie 44.0	
Total 94.0	

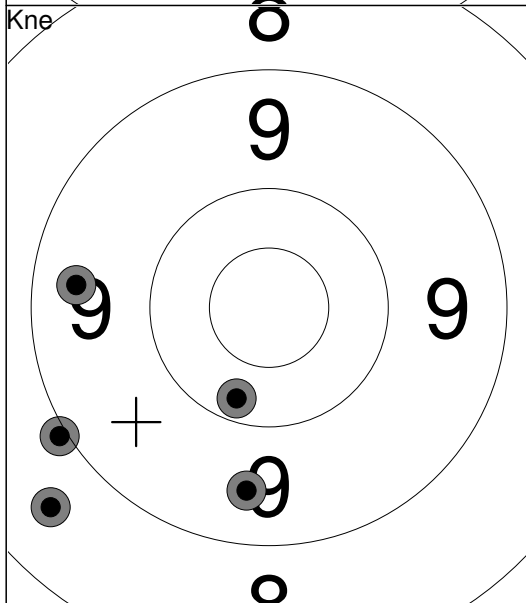

1:	9.5 ↓
2:	10.2 ↓
3:	9.4 ←
4:	9.0 ←
5:	8.5 ↙
Serie 45.0	
Total 139.0	

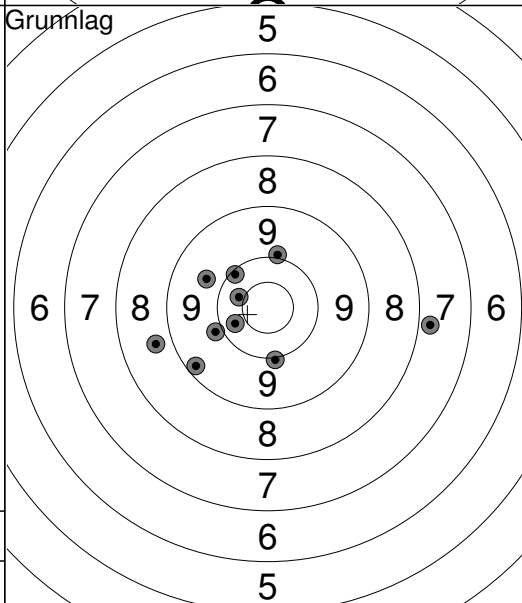

1:	9.7 ←
2:	8.7 ←
3:	7.8 →
4:	9.9 ←
5:	9.2 ↙
6:	10.4 ←
7:	10.0 ↑
8:	10.0 ↓
9:	10.3 ↙
10:	10.1 ↖
Serie 92.0	
Total 231.0	

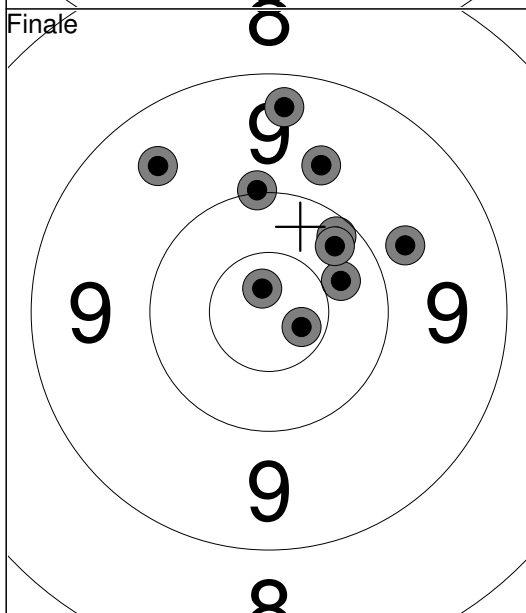

1:	10.4 ↗
2:	9.5 ↖
3:	9.7 ↑
4:	*10.7 ↘
5:	10.0 ↑
6:	9.8 ↗
7:	*10.8 ↖
8:	9.3 ↑
9:	10.2 ↗
10:	10.2 ↗
Serie 96.0	
Total 327.0	

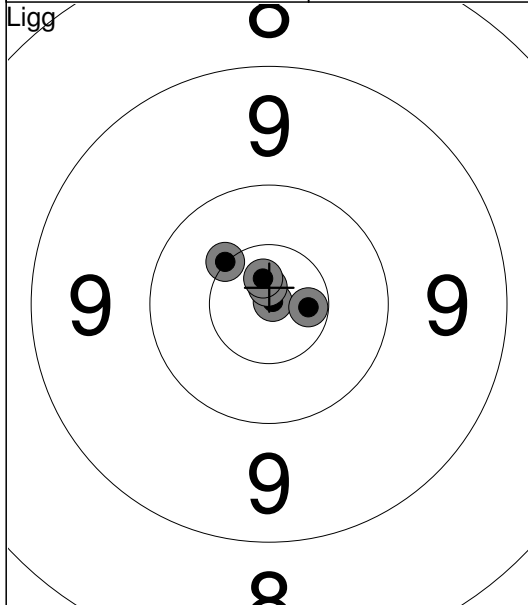

1:	*10.9 ↗
2:	*10.9 ↑
3:	*10.7 →
4:	*10.8 ↑
5:	*10.5 ↘
Serie 50.0	
Total 50.0	

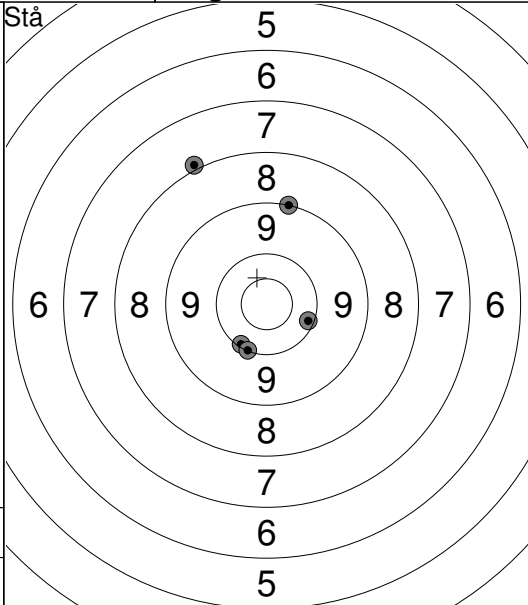

1:	10.1 ↘
2:	9.0 ↑
3:	7.9 ↗
4:	10.0 ↘
5:	10.2 ⇒
Serie 46.0	
Total 96.0	

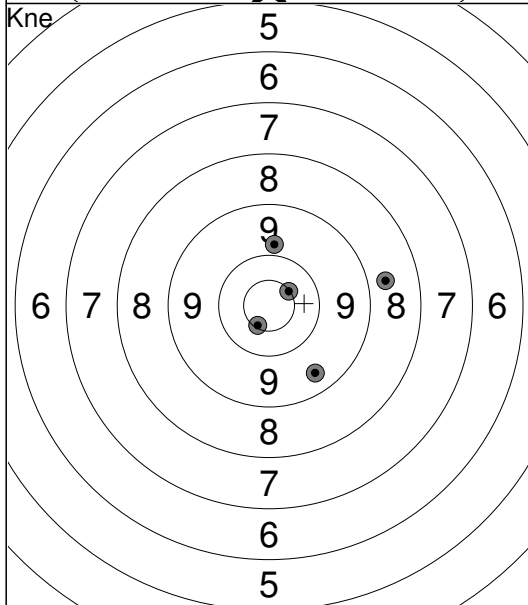

1:	9.4 ↘
2:	*10.6 ↘
3:	9.8 ↑
4:	8.7 →
5:	*10.6 ↗
Serie 46.0	
Total 142.0	

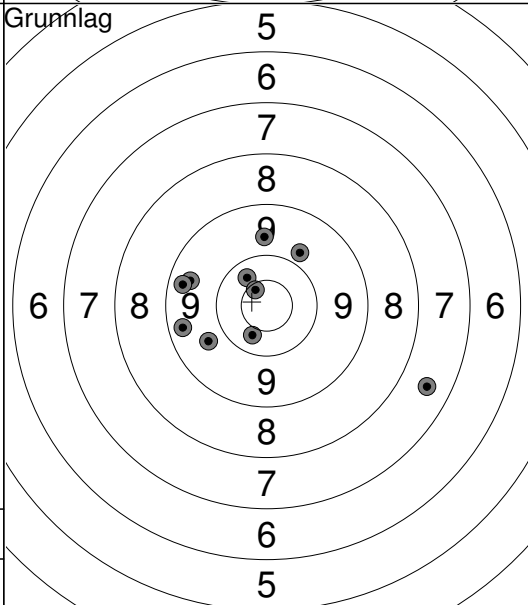

1:	9.7 ↘
2:	9.7 ↑
3:	7.5 ⇒
4:	10.4 ↘
5:	9.5 ←
6:	9.3 ←
7:	9.3 ←
8:	9.8 ↗
9:	10.4 ↗
10:	*10.6 ↘
Serie 91.0	
Total 233.0	

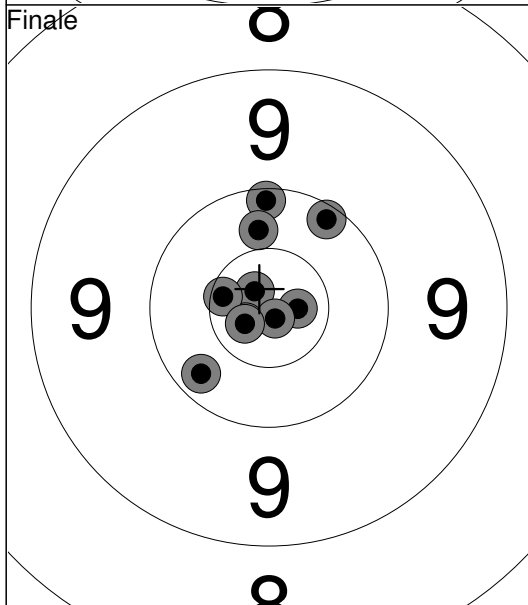

1:	*10.8 ↘
2:	10.1 ↗
3:	*10.8 ↘
4:	10.1 ↑
5:	10.4 ↑
6:	*10.8 ⇒
7:	*10.6 ←
8:	*10.9 ↘
9:	10.2 ↘
10:	*10.8 ↘
Serie 100.0	
Total 333.0	

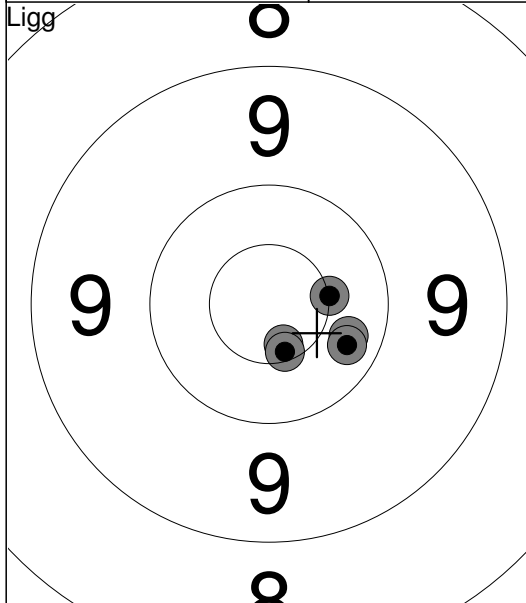

1:	10.3	➔
2:	*10.7	↘
3:	*10.5	➔
4:	10.3	➔
5:	*10.6	↘
Serie		50.0
Total		50.0

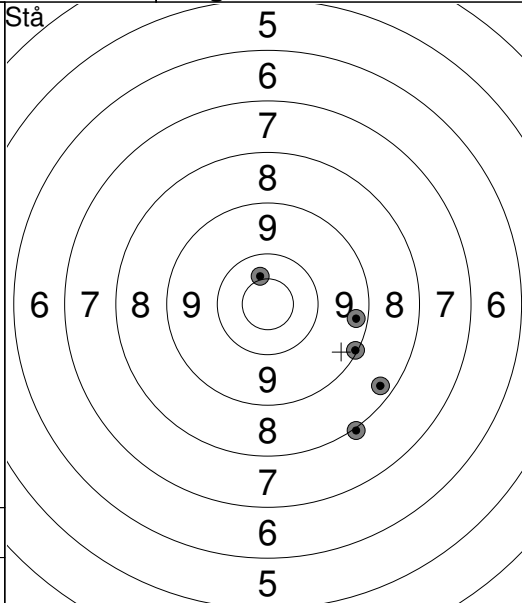

1:	8.0	↘
2:	*10.5	↗
3:	9.1	➔
4:	9.3	➔
5:	8.3	↘
Serie		44.0
Total		94.0

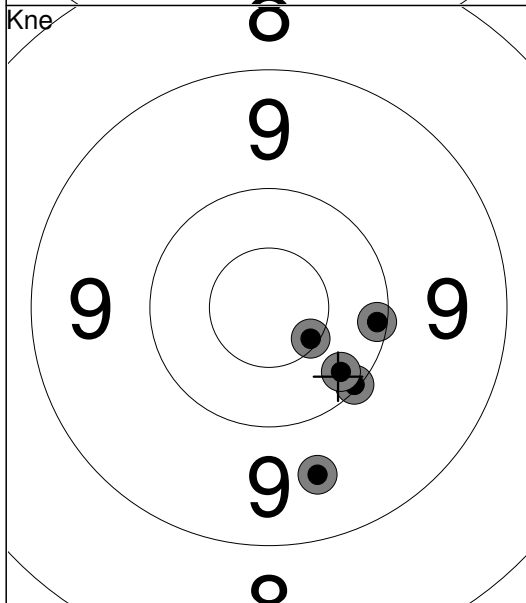

1:	10.1	➔
2:	10.1	↘
3:	10.2	↘
4:	9.6	↘
5:	*10.6	↘
Serie		49.0
Total		143.0

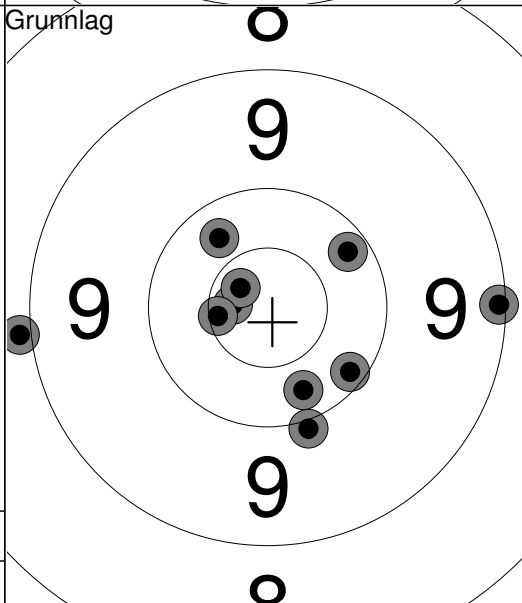

1:	10.3	↗
2:	9.1	➔
3:	10.0	↘
4:	8.9	←
5:	10.3	↘
6:	10.2	↗
7:	*10.7	←
8:	*10.7	↗
9:	*10.6	←
10:	10.1	↘
Serie		97.0
Total		240.0

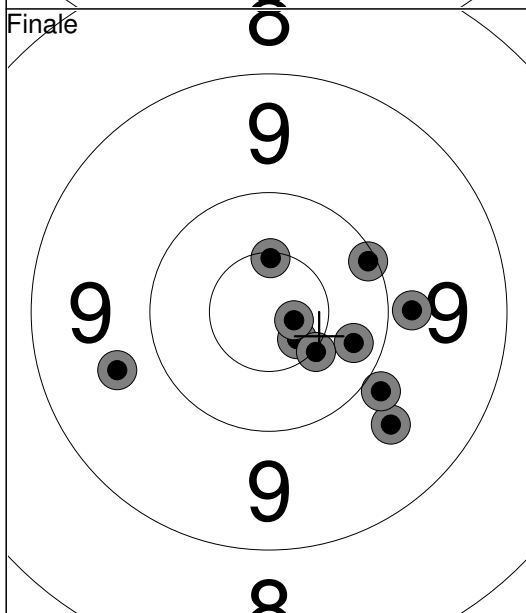

1:	10.1	➔
2:	*10.6	↗
3:	9.8	➔
4:	9.6	↘
5:	10.3	➔
6:	9.9	↘
7:	*10.7	↘
8:	9.7	←
9:	*10.5	↘
10:	*10.8	➔
Serie		96.0
Total		336.0

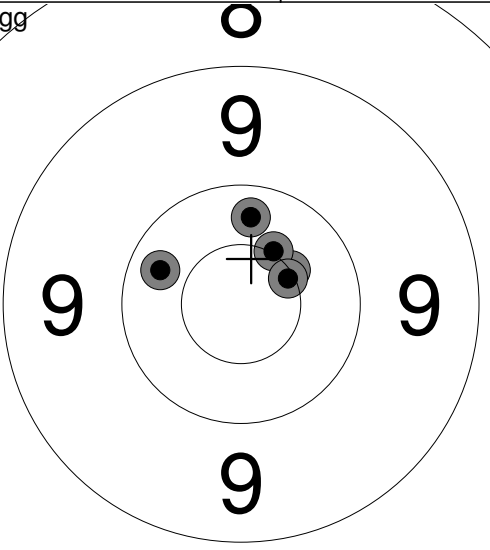
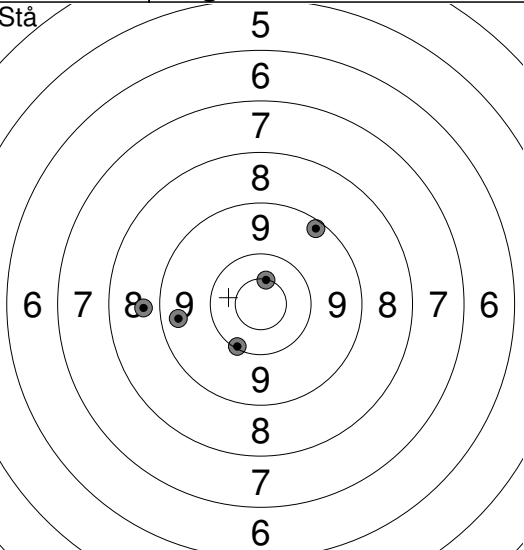
<p>Ligg</p> 	<p>Stå</p> 	<p>1: 10.3 ←</p> <p>2: *10.5 ↗</p> <p>3: *10.5 ↗</p> <p>4: *10.6 ↗</p> <p>5: 10.3 ↑</p>
Serie 50.0		1: 9.2 ↗
Total 50.0		2: *10.5 ↑
		3: 9.4 ←
		4: 8.7 ←
		5: 10.1 ↓
	Serie 46.0	
	Total 96.0	

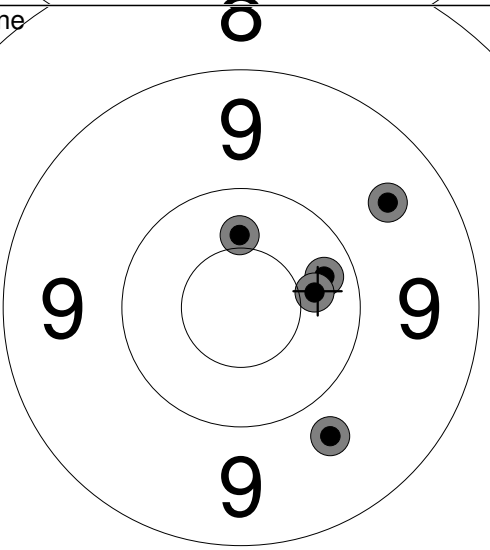
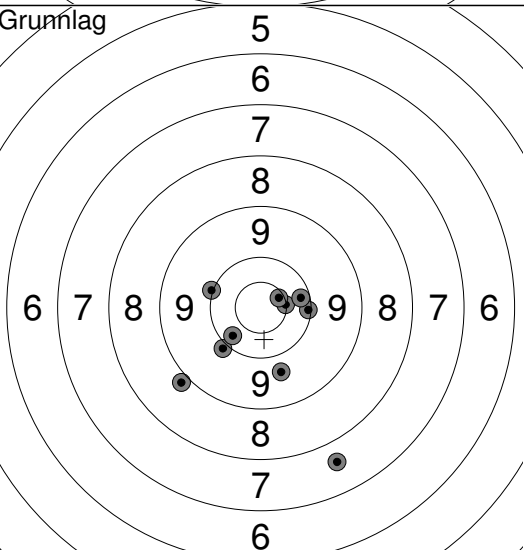
<p>Kne</p> 	<p>Grunnlag</p> 	<p>1: 10.4 ↑</p> <p>2: 9.5 ↗</p> <p>3: 10.3 →</p> <p>4: 9.7 ↓</p> <p>5: 10.4 →</p>
Serie 48.0		1: 7.6 ↓
Total 144.0		2: 9.7 ↓
		3: 9.9 ↙
		4: 8.9 ↙
		5: 10.3 ↙
		6: 10.0 ←
		7: *10.5 →
		8: *10.6 ↗
		9: 10.1 →
		10: 10.2 →
	Serie 93.0	
	Total 237.0	

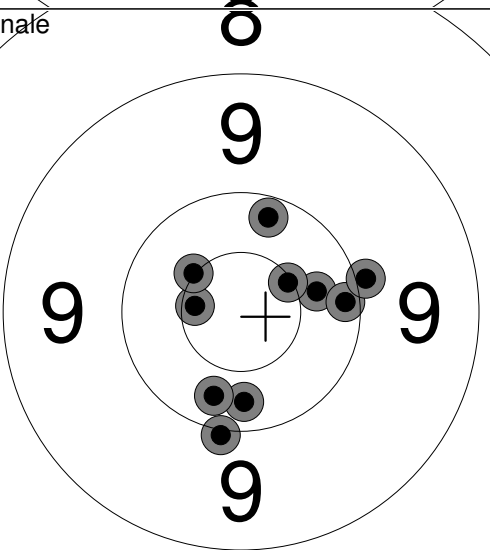
<p>Finale</p> 	<p>1: *10.6 ←</p> <p>2: 10.4 →</p> <p>3: 10.2 ↑</p> <p>4: 10.1 →</p> <p>5: 10.0 ↓</p> <p>6: 10.3 ↓</p> <p>7: *10.6 ↗</p> <p>8: *10.5 ↖</p> <p>9: 10.3 ↓</p> <p>10: 9.9 →</p>	
Serie 99.0		
Total 336.0		

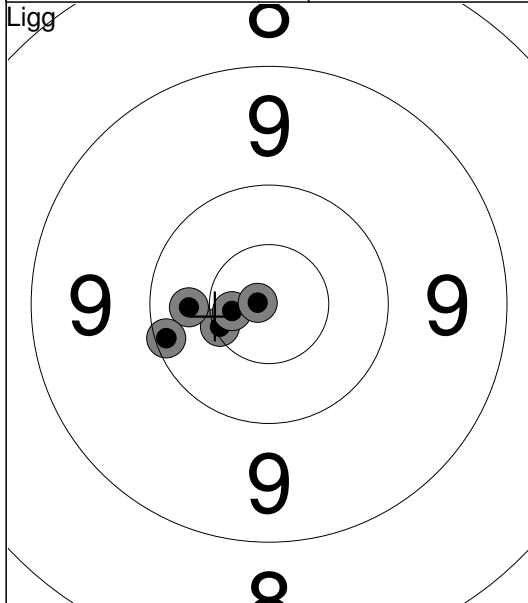

1:	*10.6 ↙
2:	*10.7 ↙
3:	10.4 ←
4:	10.1 ←
5:	*10.9 ↙
Serie 50.0	
Total 50.0	

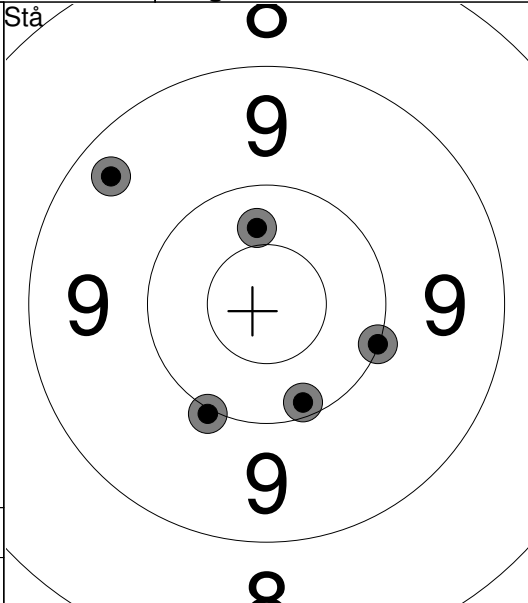

1:	10.2 ↓
2:	10.0 ↓
3:	9.3 ↖
4:	10.0 →
5:	10.4 ↑
Serie 49.0	
Total 99.0	

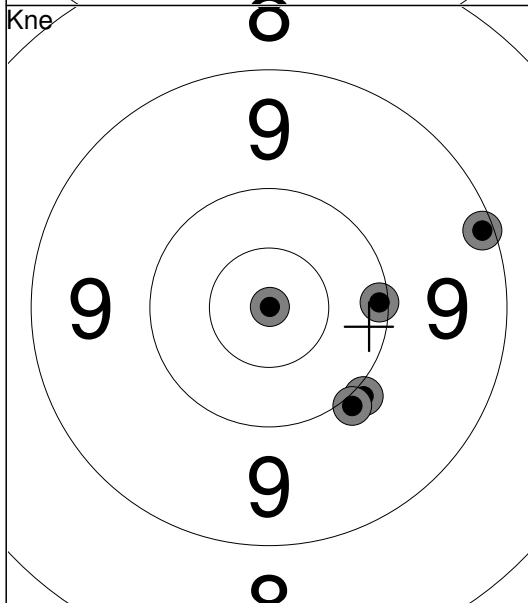

1:	9.1 →
2:	9.9 ↓
3:	10.1 →
4:	10.0 ↓
5:	*10.9 →
Serie 48.0	
Total 147.0	

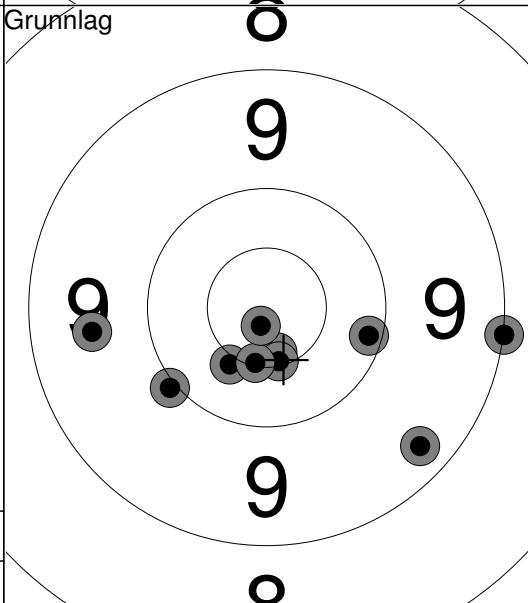

1:	9.0 →
2:	9.3 ↓
3:	10.0 ↙
4:	10.1 →
5:	9.6 ←
6:	*10.5 ↙
7:	*10.6 ↓
8:	*10.6 ↓
9:	*10.6 ↓
10:	*10.9 ↓
Serie 97.0	
Total 244.0	

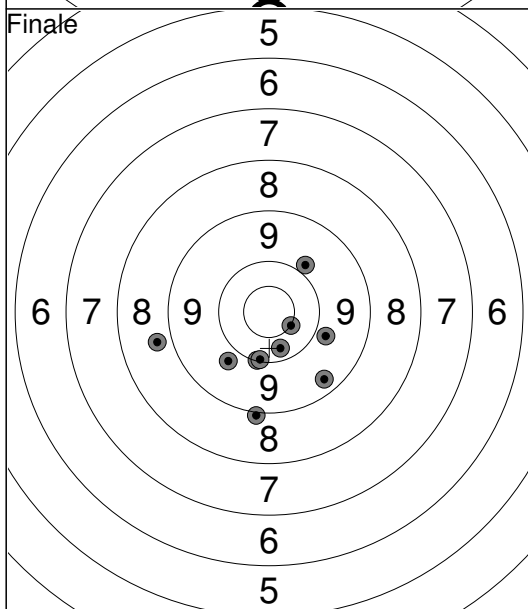

1:	9.9 ↗
2:	*10.5 ↘
3:	10.0 ↓
4:	10.3 ↓
5:	9.8 ↙
6:	10.1 ↓
7:	8.7 ←
8:	9.3 ↓
9:	9.0 ↓
10:	9.8 →
Serie 93.0	
Total 337.0	